



# TECHNICAL BOOKLET



[wds.ua](https://wds.ua) 



**Window with one sash**

Connection **Sash 047 // Frame 046 // Fixed frame 077**

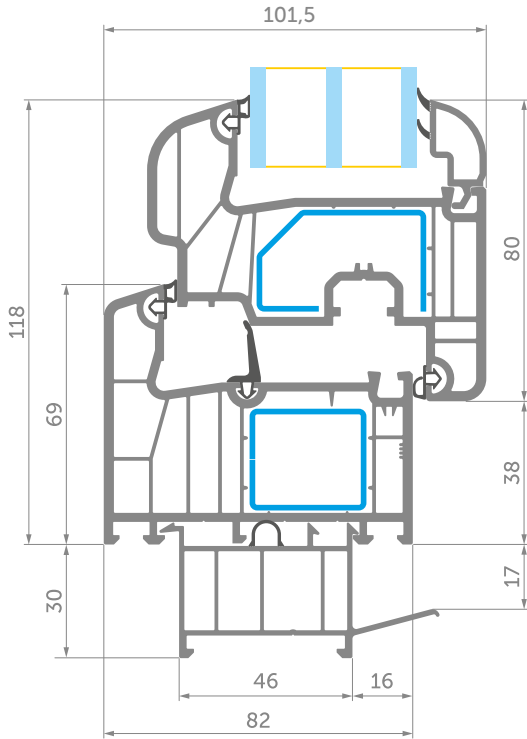

**Window with one sash and mullion**

Connection **Sash 047 // Mullion 048**

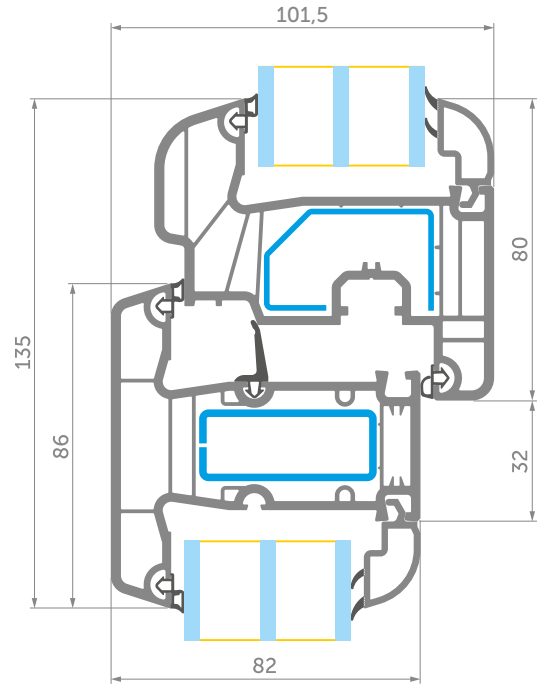

**Window with two sashes and stulp**

Connection **Sash 047 // Stulp 068 // Sash 047**

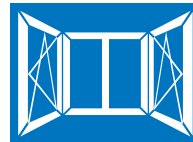
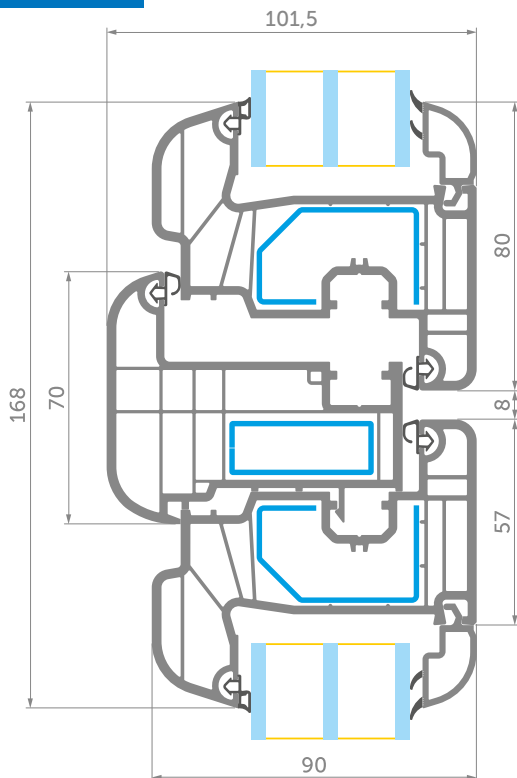

**Window with two sashes and mullion**

Connection **Sash 047 // Mullion 048 // Sash 047**

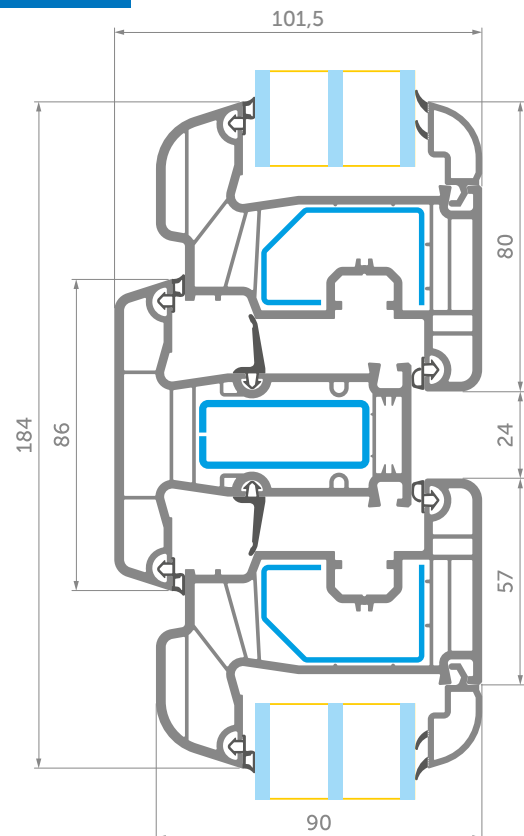



## Window with one sash

Connection Sash 080 // Frame 046 // Fixed frame 077

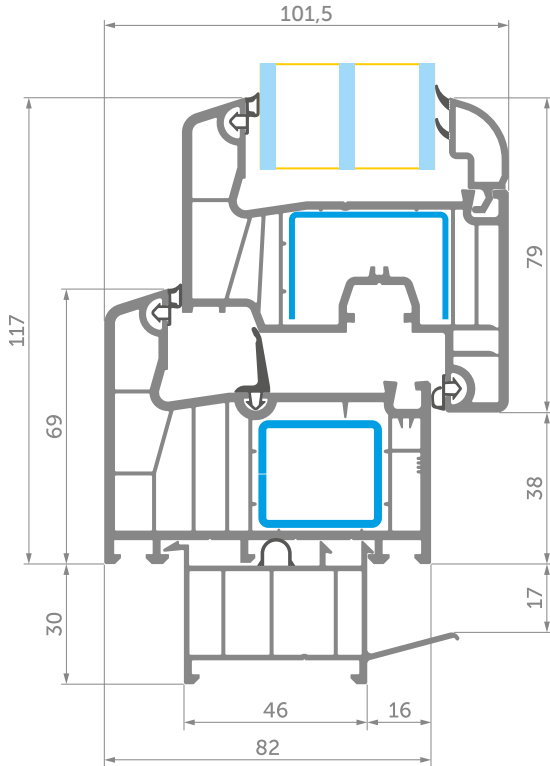

## Window with one sash and mullion

Connection Sash 080 // Mullion 048

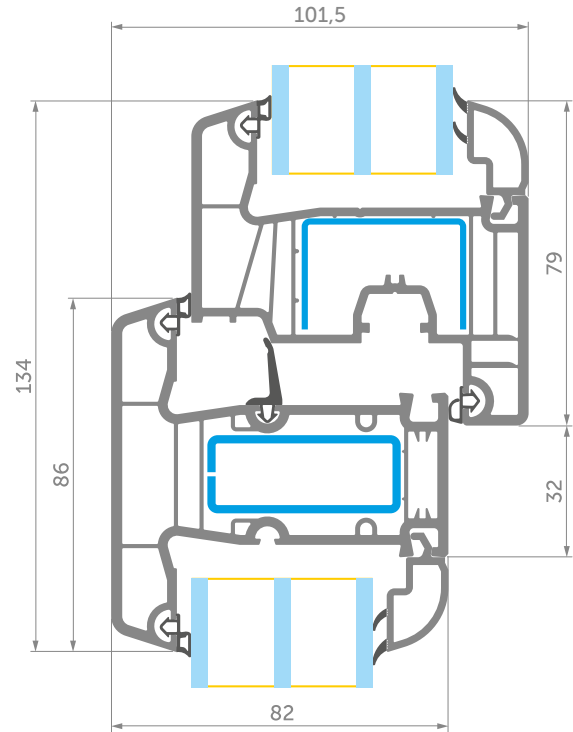

## Window with two sashes and stulp

Connection Sash 080 // Stulp 068 // Sash 080

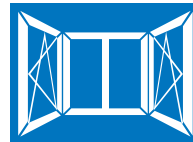
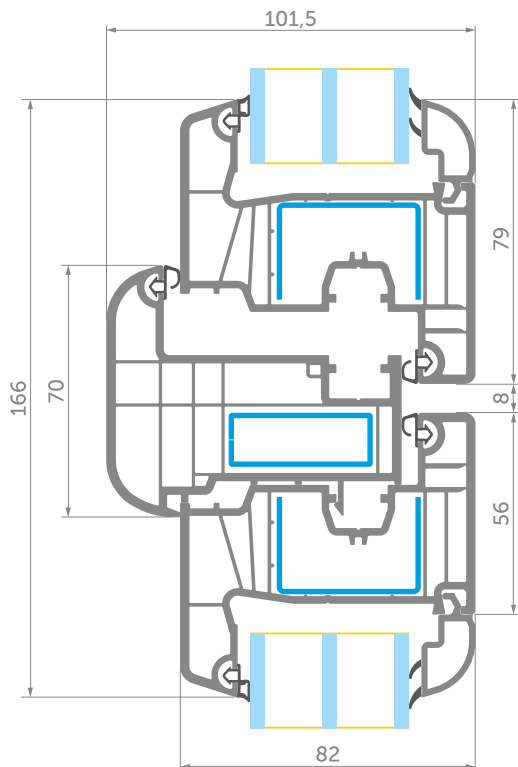

## Window with two sashes and mullion

Connection Sash 080 // Mullion 048 // Sash 080

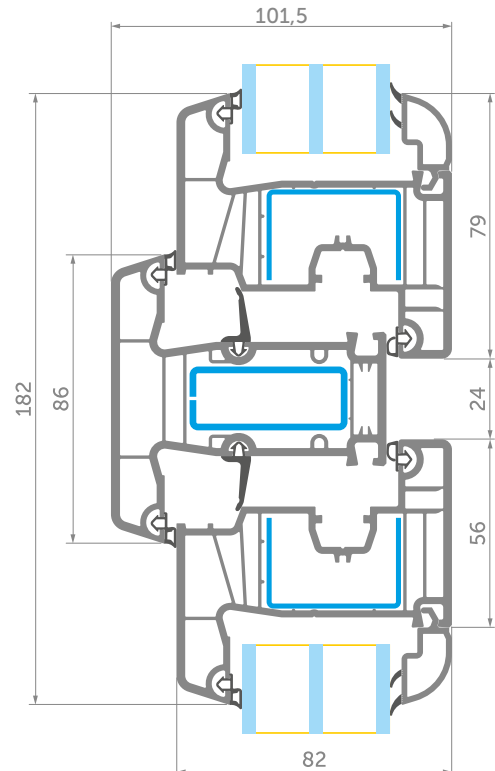



**Window with one sash**

Connection Sash 060(093) // Frame 059(092) // Fixed frame 077

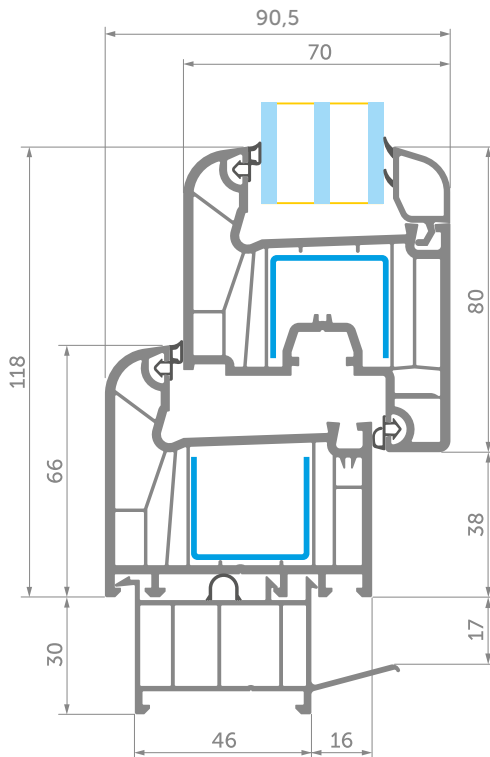

**Window with one sash and mullion**

Connection Sash 060(093) // Mullion 058

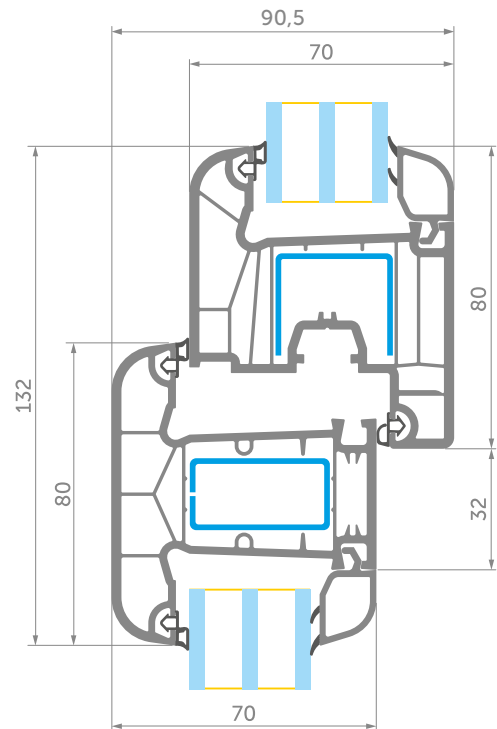

**Window with two sashes and stulp**

Connection Sash 060(093) // Stulp 054 // Sash 060(093)

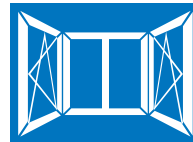
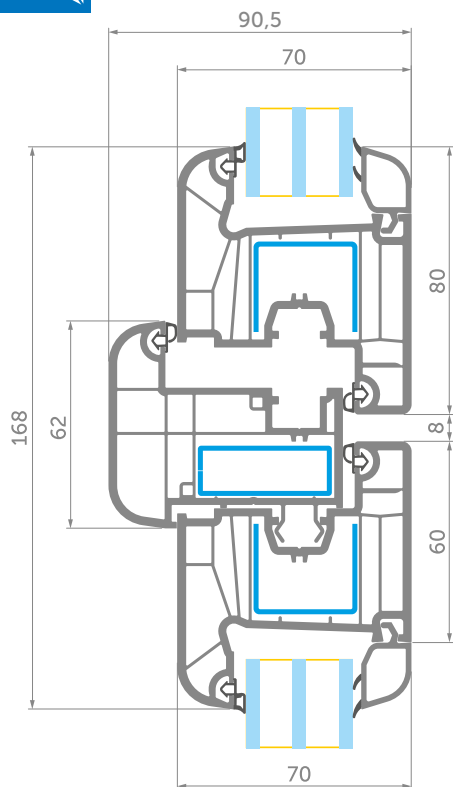

**Window with two sashes and mullion**

Connection Sash 060(093) // Mullion 058 // Sash 060(093)

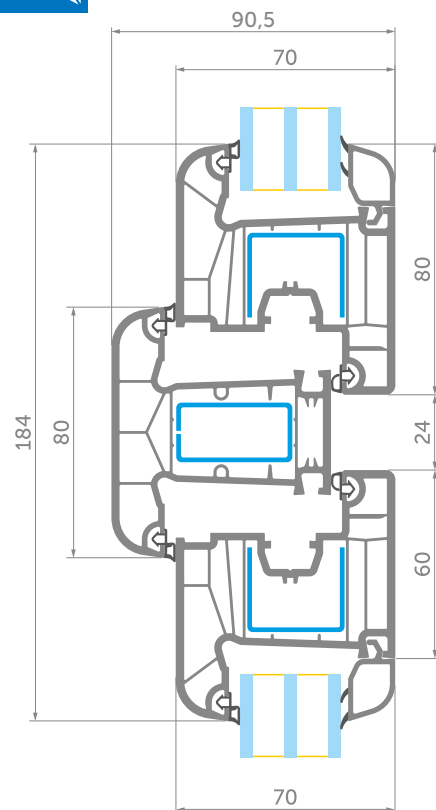



## Window with one sash

Connection 1: Sash 089 // Frame 088 // Fixed frame 050

Connection 2: Sash 089 // Renovative frame 081

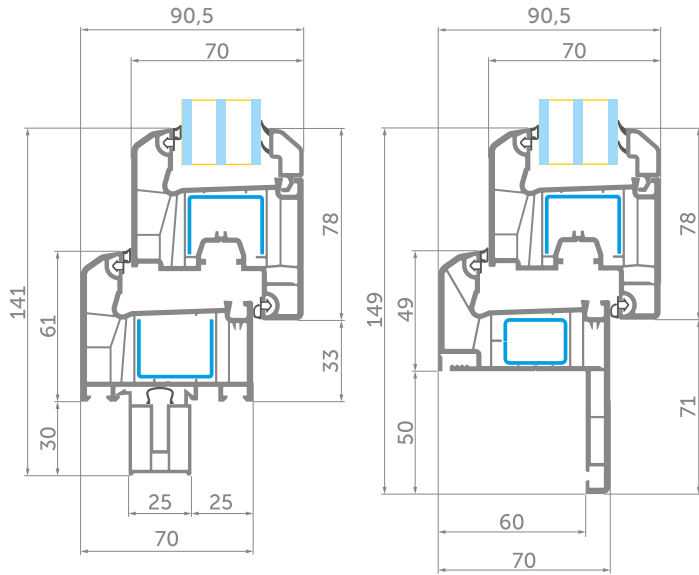

Connection 1

Connection 2



## Window with one sash and mullion

Connection Sash 089 // Mullion 063

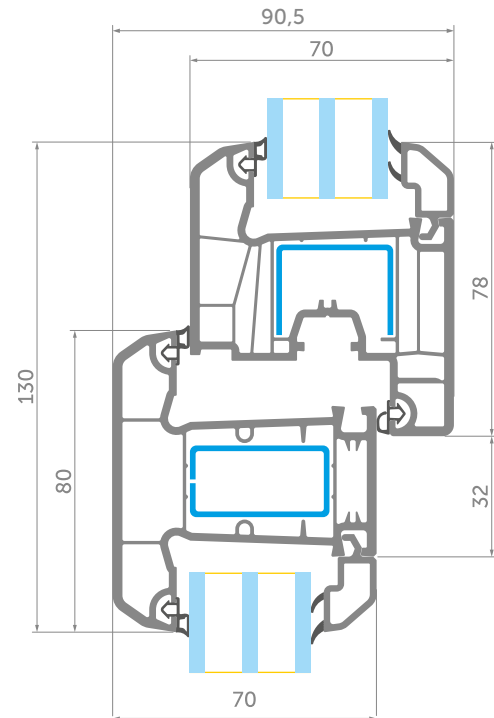

## Window with two sashes and stulp

Connection Sash 089 // Stulp 054 // Sash 089

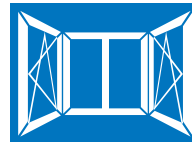
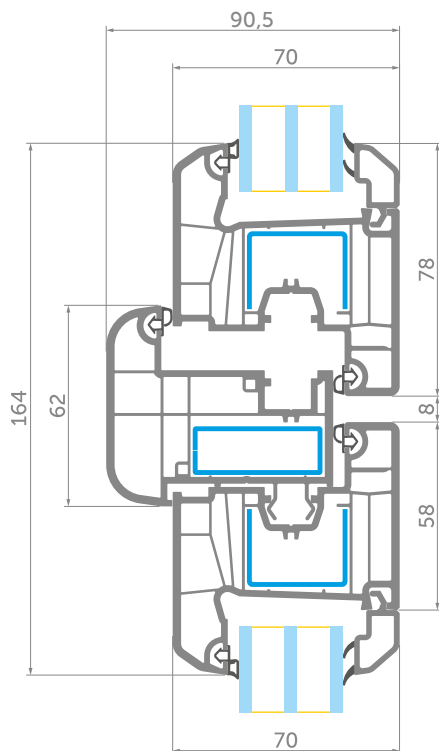

## Window with two sashes and mullion

Connection Sash 089 // Mullion 063 // Sash 089

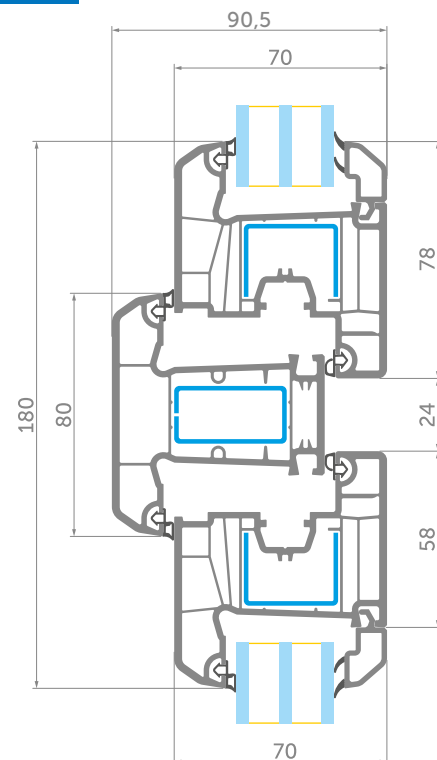



## Window with one sash

Connection Sash 087 // Frame 086 // Fixed frame 050

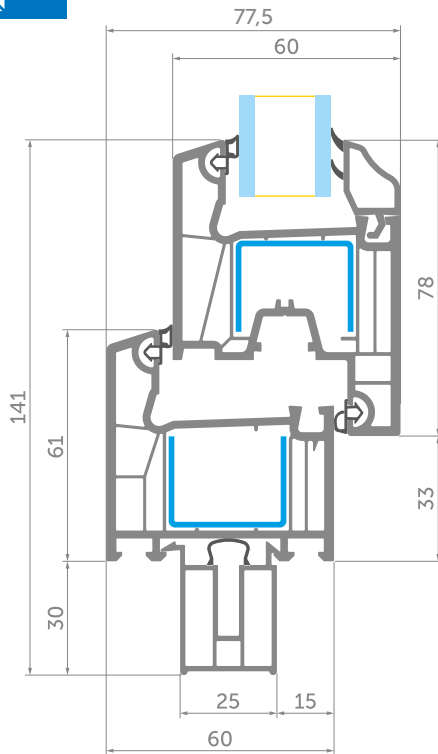

## Window with one sash and mullion

Connection Sash 087 // Mullion 125

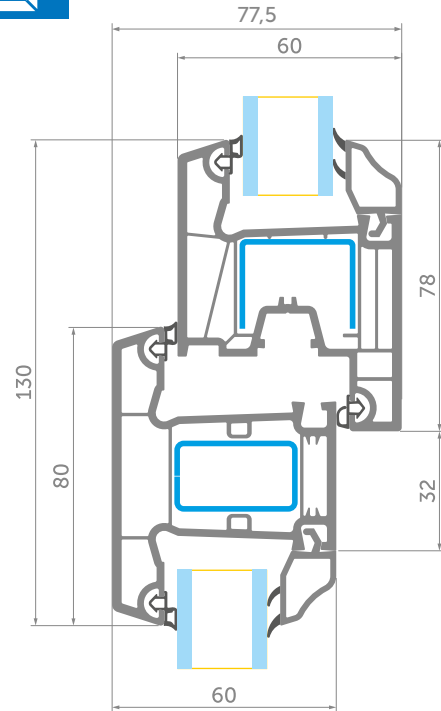

## Window with two sashes and stulp

Connection Sash 087 // Stulp 012 // Sash 087

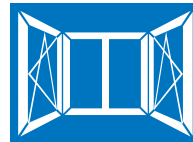
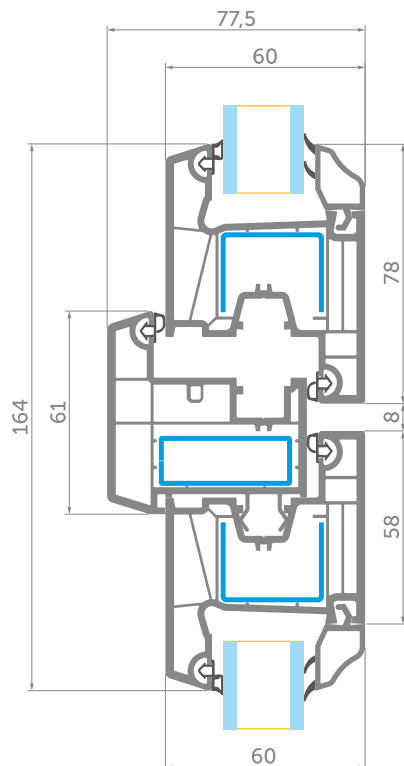

## Window with two sashes and mullion

Connection Sash 087 // Mullion 125 // Sash 087

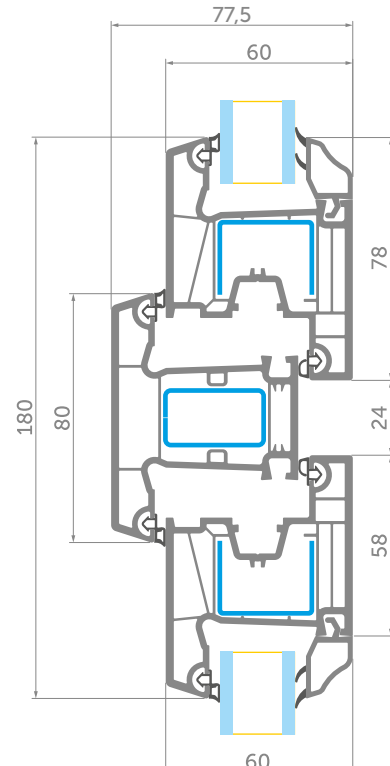

# WDS Doors 70 mm



## Entrance door outside opening with threshold

Connection Door sash outside opening 045  
// Composite threshold with thermal insert  
D000114

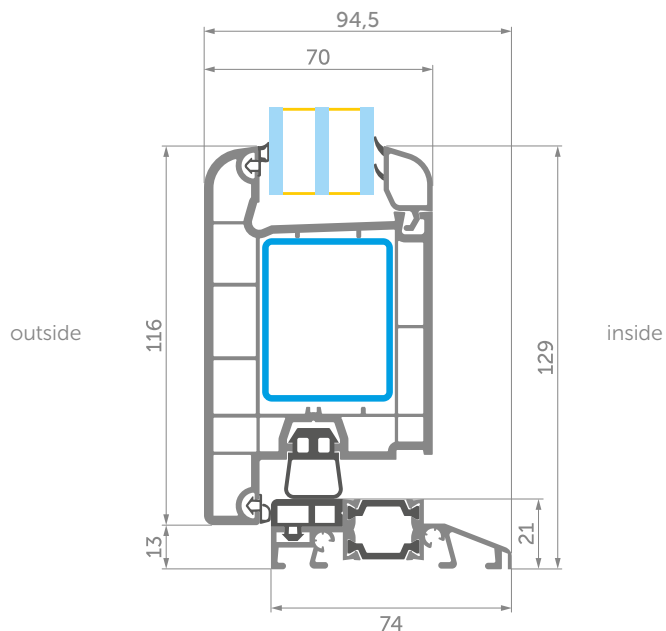

## Entrance door inside opening with threshold

Connection Door sash inside opening 078  
// Composite threshold with thermal insert  
D000114

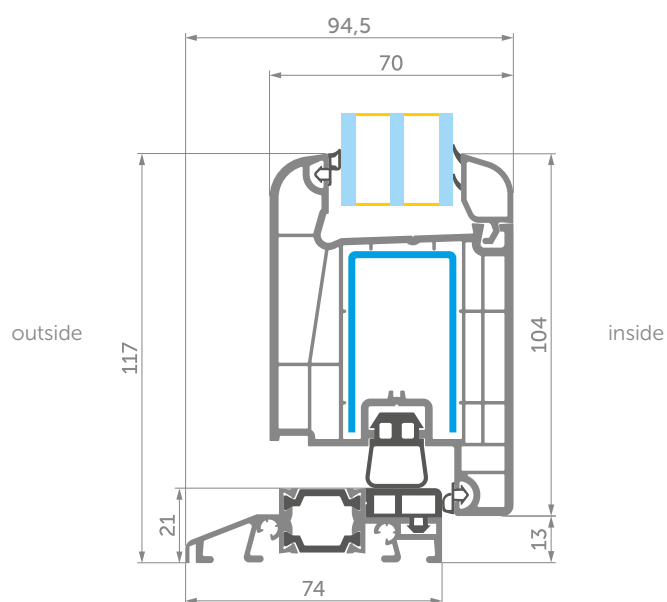

## Entrance door outside opening with frame

Connection Door sash outside opening 045 //  
Frame 059(092)

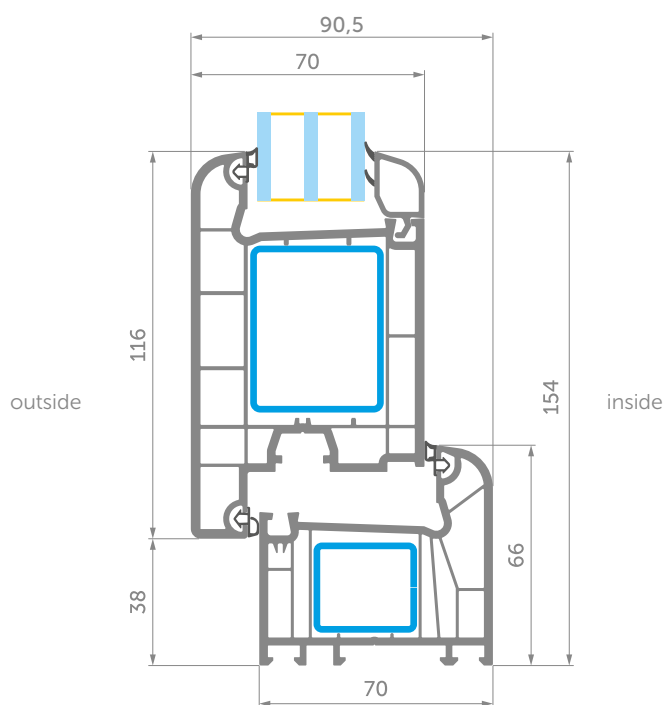

## Entrance door inside opening with frame

Connection Door sash inside opening 078 //  
Frame 059(092)

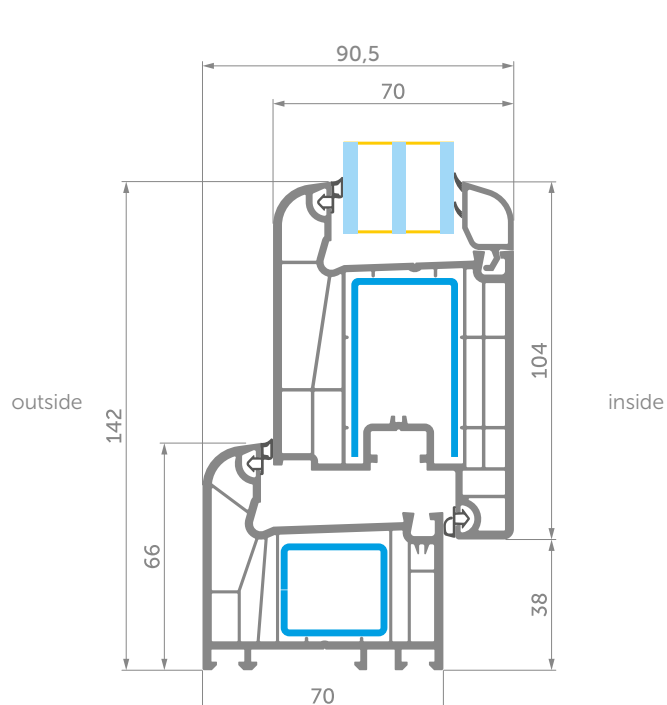



### Entrance door outside opening with door frame

Connection Door sash outside opening 045 // Door frame 082

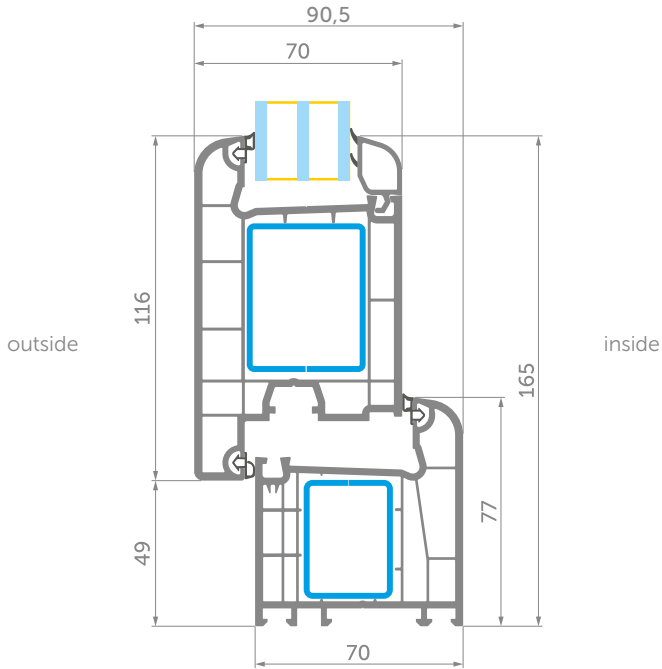

### Entrance door inside opening with door frame

Connection Door sash inside opening 078 // Door frame 082

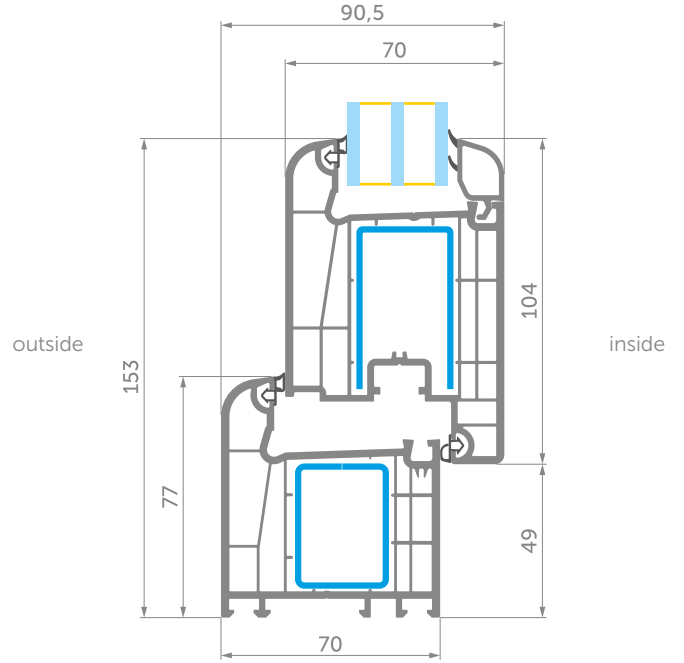

### Entrance door outside opening with stulp

Connection Door sash outside opening 045 // Stulp 054 // Door sash outside opening 045

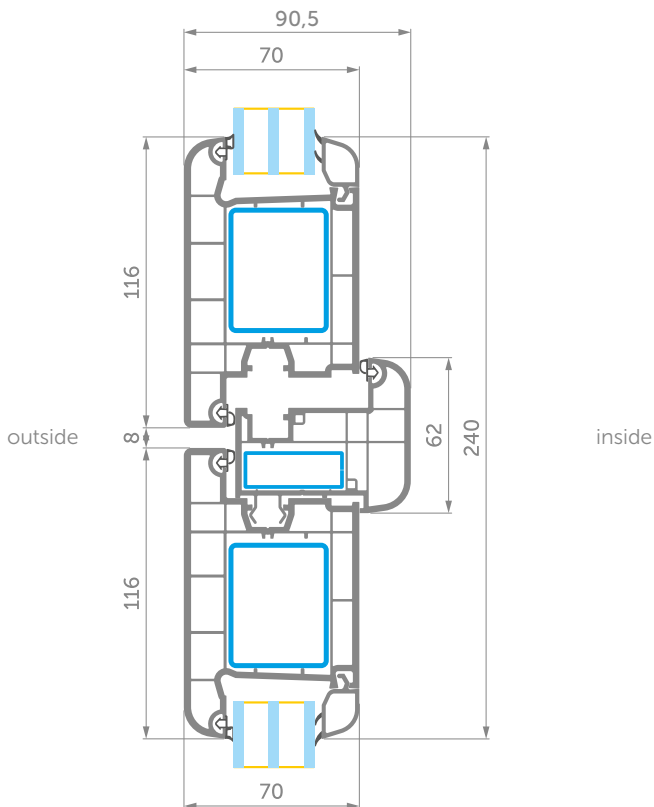

### Entrance door inside opening with stulp

Connection Door sash inside opening 078 // Stulp 054 // Door sash inside opening 078

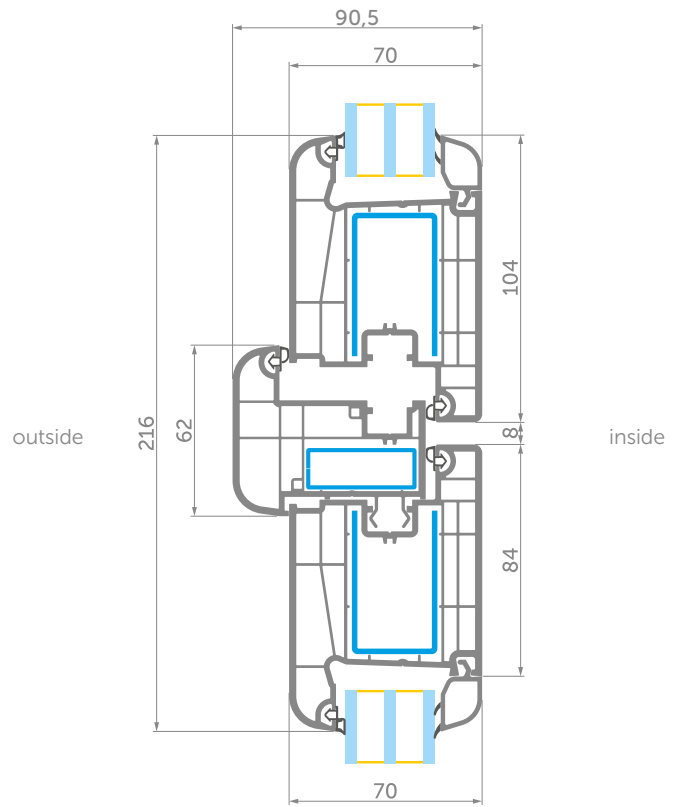



# WDS Doors 60 mm



## Interior door outside opening with threshold

Connection Door sash outside opening 056 // Threshold D000065

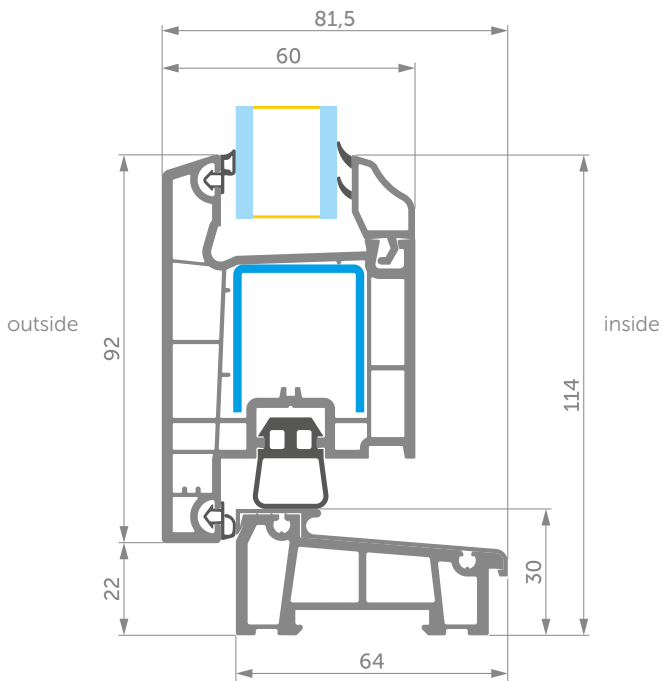

## Entrance door inside opening with threshold

Connection Door sash inside opening 008 // Threshold D000065

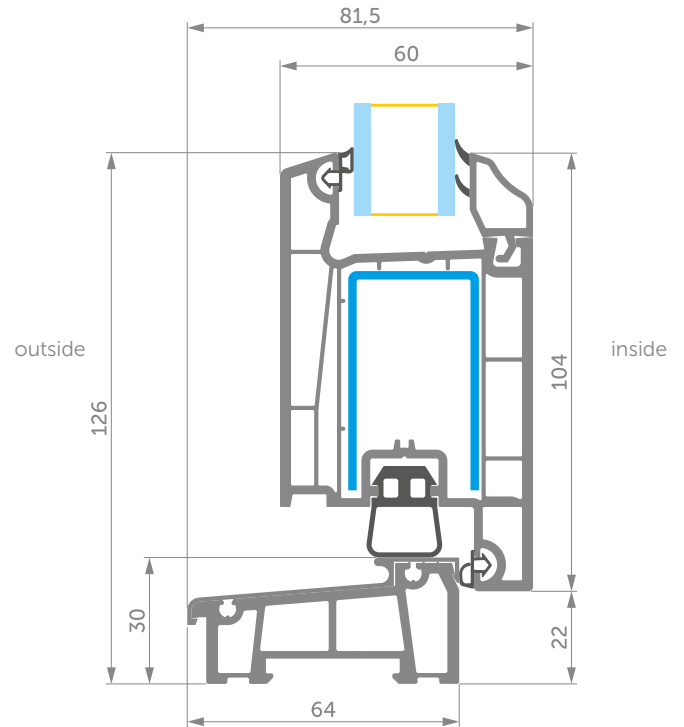

## Entrance door outside opening with threshold

Connection Door sash outside opening 007 // Threshold D000065

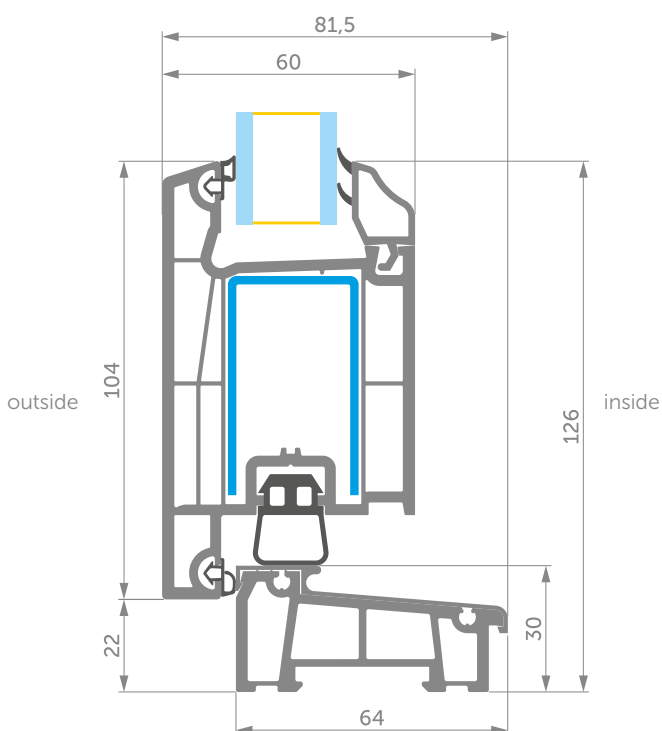

## Entrance door outside opening with threshold

Connection Door sash outside opening 036 // Threshold D000065

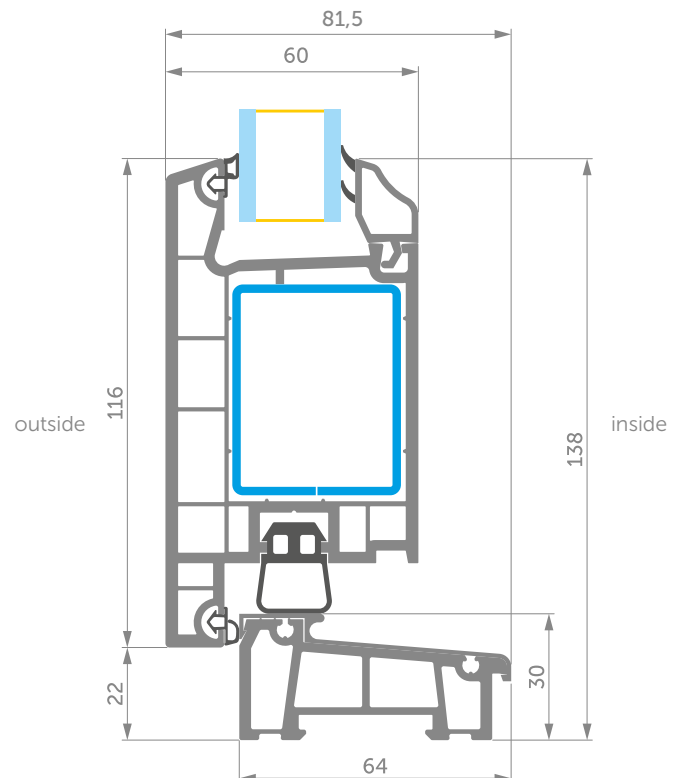



### Interior door outside opening with frame

Connection Door sash outside opening 056 // Frame 001

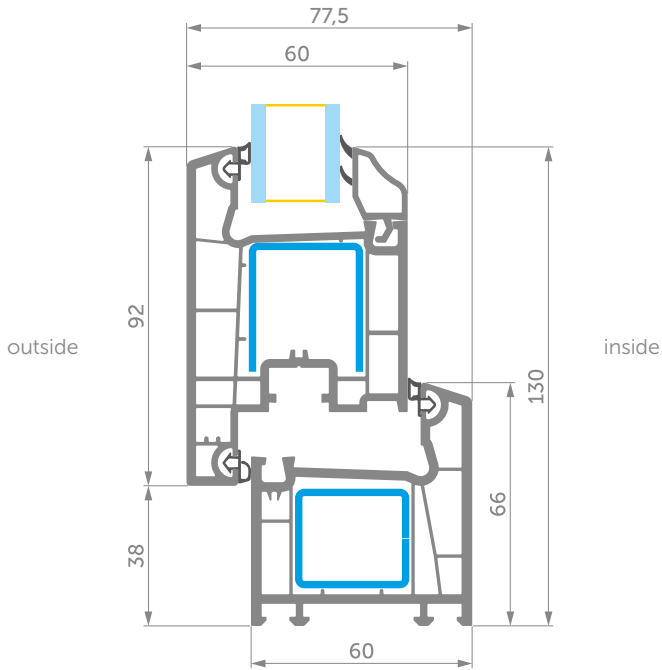

### Entrance door inside opening with frame

Connection Door sash inside opening 008 // Frame 001

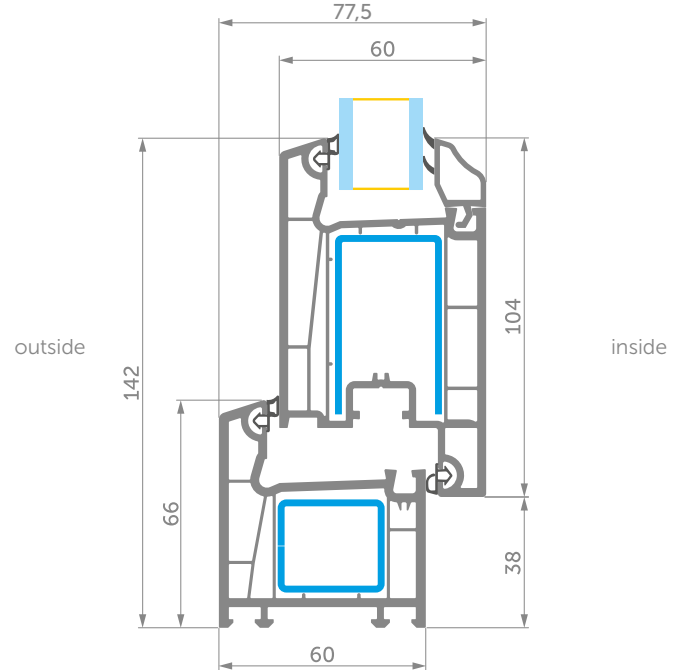

### Entrance door outside opening with frame

Connection Door sash outside opening 007 // Frame 001

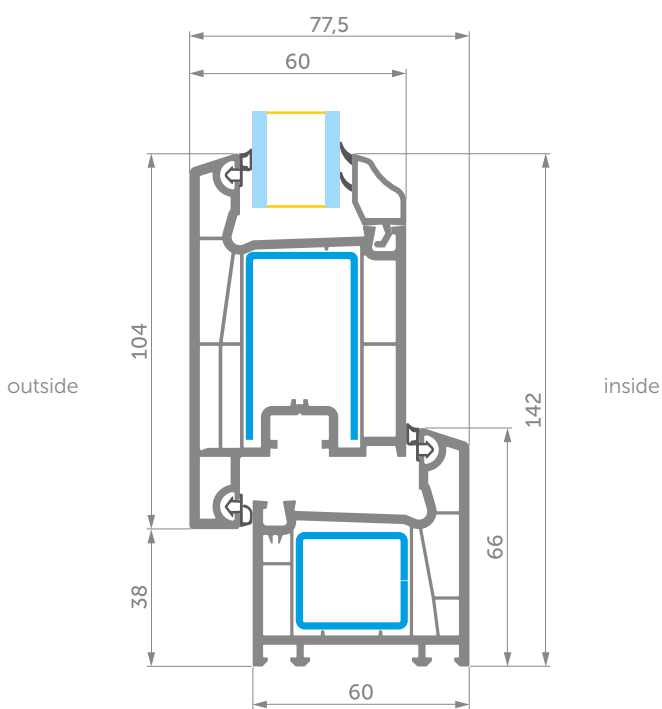

### Entrance door outside opening with frame

Connection Door sash outside opening 036 // Frame 001

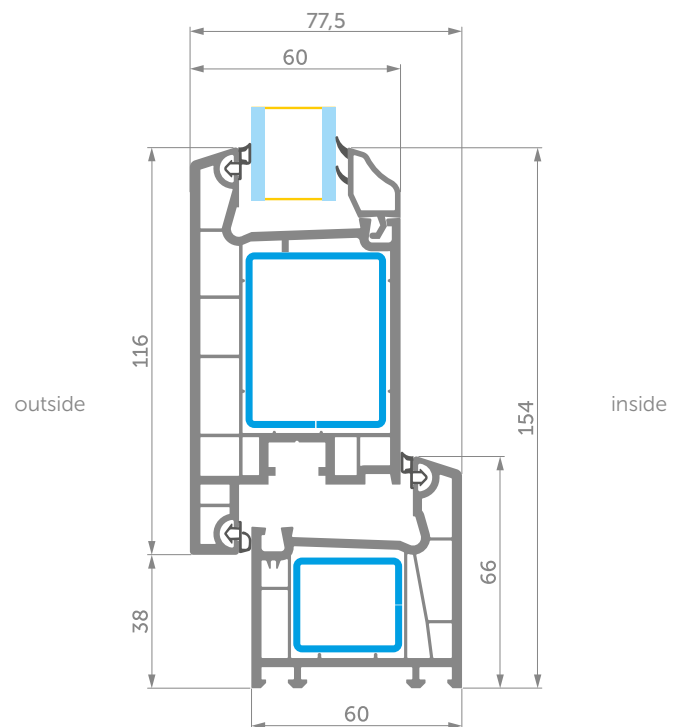



### Interior door outside opening with stulp

Connection Door sash outside opening 056 // Stulp 012 // Door sash outside opening 056

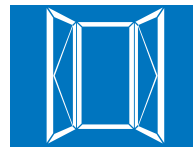
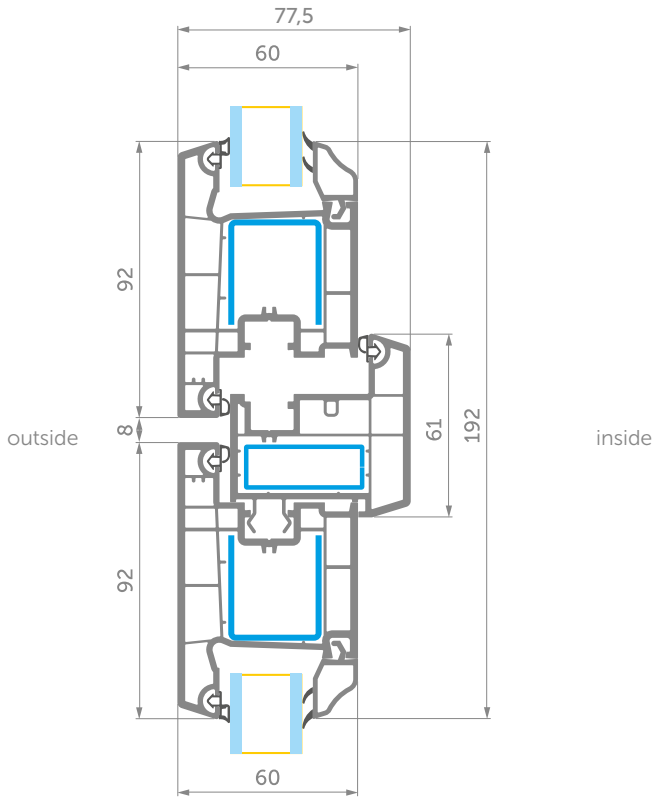

### Entrance door inside opening with stulp

Connection Door sash inside opening 008 // Stulp 012 // Door sash inside opening 008

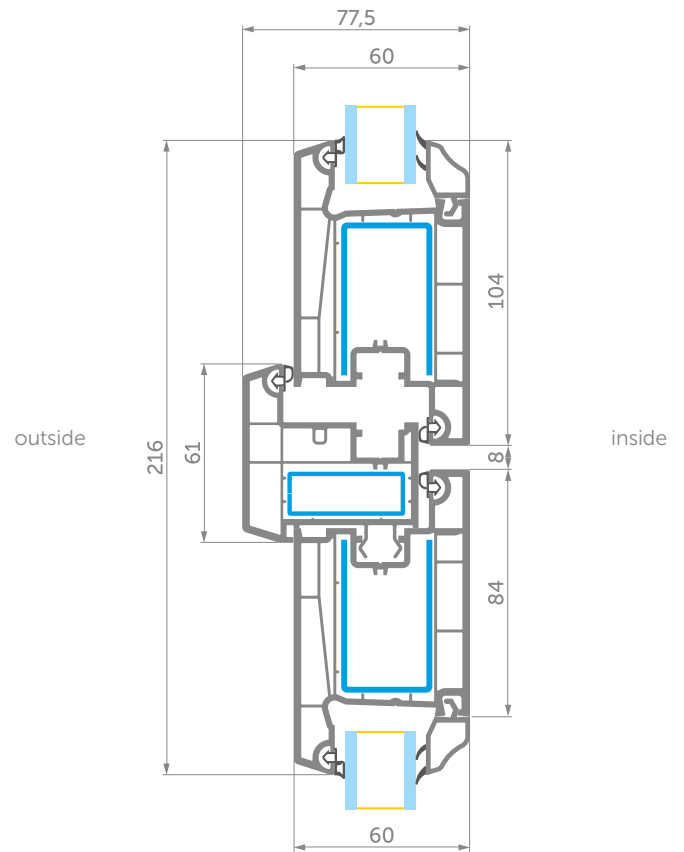

### Entrance door outside opening with stulp

Connection Door sash outside opening 007 // Stulp 012 // Door sash outside opening 007

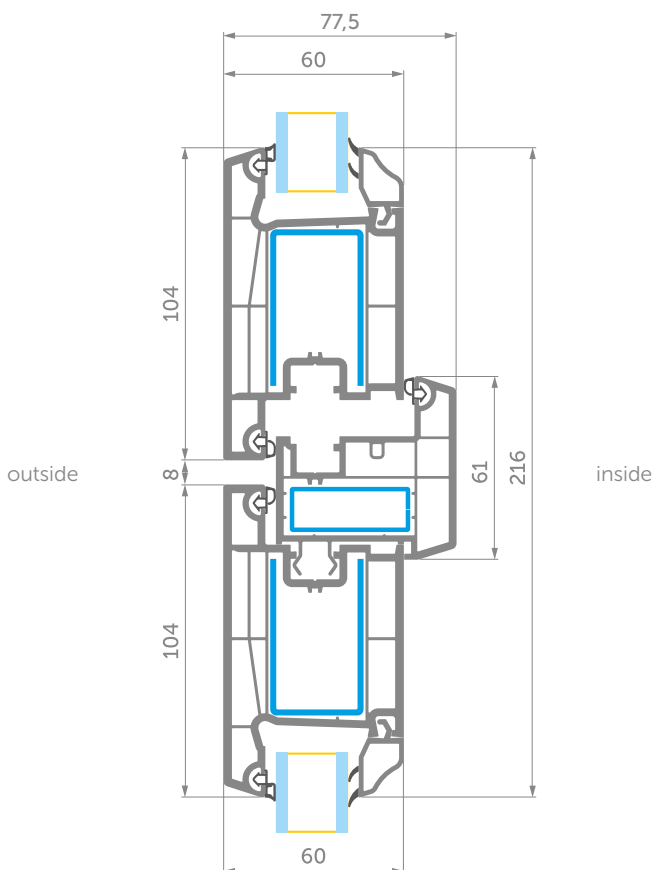

### Entrance door outside opening with stulp

Connection Door sash outside opening 036 // Stulp 012 // Door sash outside opening 036

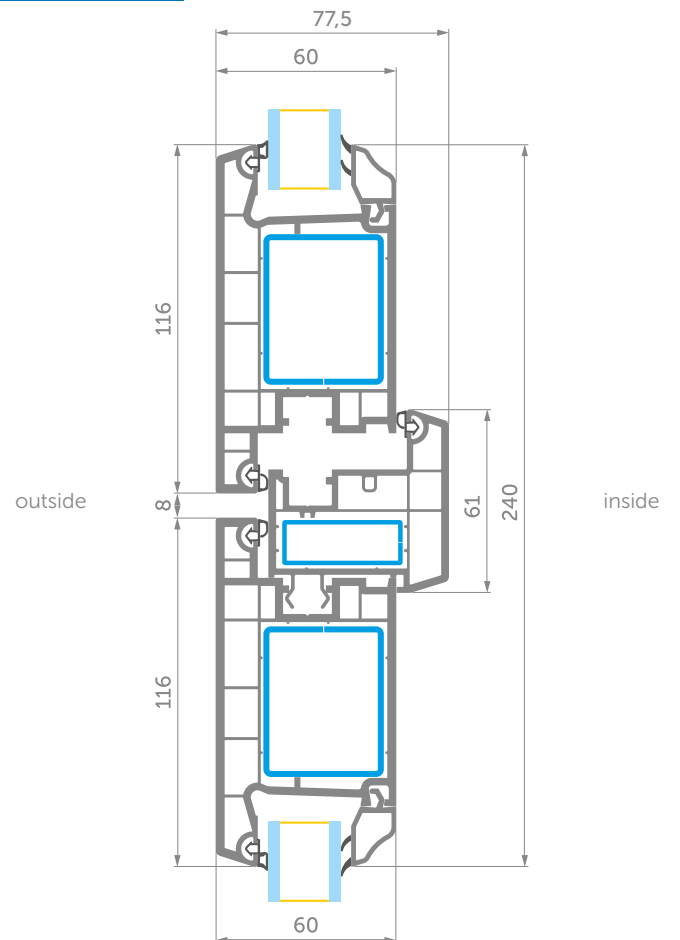

**WDS 8S**

**WDS 7S**

**WDS 6S**

**WDS 5S**

## WDS Laminated profile systems



Film color	Gasket color	Profile color	Profile color	Profile color	Profile color
Sheffield Oak concrete	Grey	● Grey	● Grey	—	—
Turner Oak	Beige	● Beige	● Beige	—	—
Sheffield Oak alpine	Grey	○ White	○ White	—	—
Sheffield oak	Grey	○ White	○ White	○ White	○ White
AnTEAK	Black	● Grey	● Grey	● Grey	○ White
Natural oak	Beige	● Beige	● Beige	● Beige	● Beige
Golden oak	Beige	● Beige	● Beige	● Beige	● Beige
Walnut	Beige	● Beige	● Beige	● Beige	● Beige
Montana oak	Black	● Beige	● Beige	● Beige	● Beige
Dark cherry	Black	● Beige	● Beige	● Beige	● Beige
Silver metallic	Grey	● Grey	● Grey	● Grey	○ White
Grey matte	Grey	● Grey	● Grey	● Grey	○ White
Basalt	Black	● Grey	● Grey	● Grey	○ White
Quartz	Black	● Grey	● Grey	● Grey	○ White
Umbra matte	Black	● Grey	● Grey	● Grey	○ White
Anthracite	Black	● Grey	● Grey	● Grey	○ White
Anthracite grey matte	Black	● Grey	● Grey	● Grey	○ White
Anthracite grey sand	Black	● Grey	● Grey	● Grey	○ White
Black brown matte	Black	● Grey	● Grey	● Grey	○ White



[View all colors](#)

## Mullion static values

A mullion acts as a divider in a window or a door. This element of the structure bears maximum wind loads and requires calculation of static values.

The possibility of mullion use depends on the type of the structure, building where it will be installed and area category.

82  
mm

WDS 8S

Mullion 048

$J_x = 4,9 \text{ cm}^4$ ,  $J_y = 1,2 \text{ cm}^4$

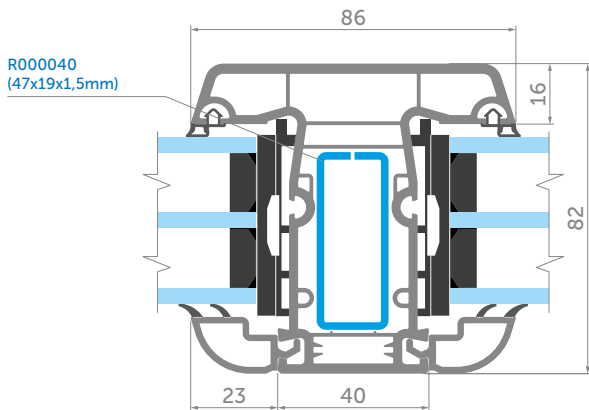

70  
mm

WDS 7S

Mullion 058

$J_x = 2,6 \text{ cm}^4$ ,  $J_y = 0,9 \text{ cm}^4$

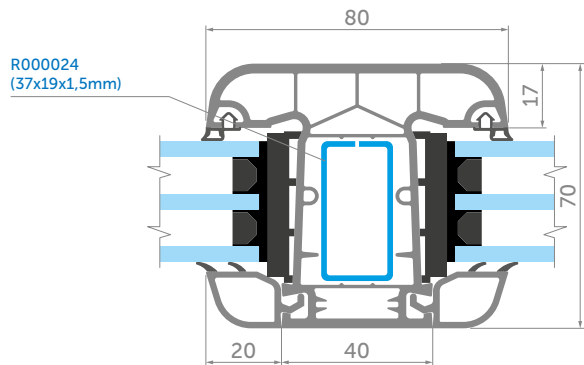

70  
mm

WDS 6S

Mullion 063

$J_x = 2,6 \text{ cm}^4$ ,  $J_y = 0,9 \text{ cm}^4$

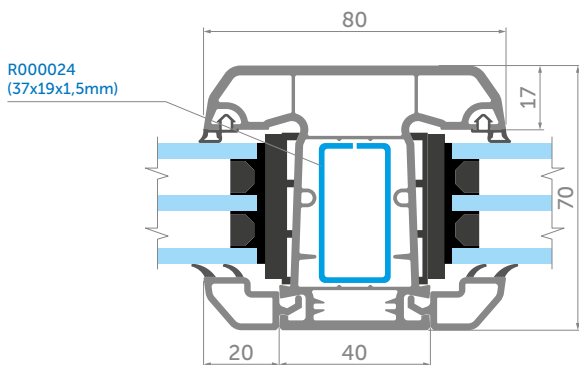

60  
mm

WDS 5S

Mullion 125

$J_x = 2,0 \text{ cm}^4$ ,  $J_y = 0,8 \text{ cm}^4$

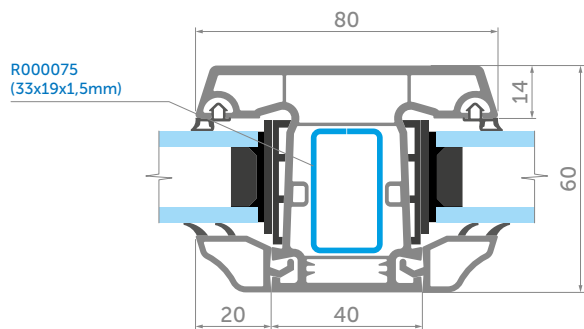

# Connection with H-connector

**WDS H-connector can be used for profile systems with 60, 70, 82 mm mounting width.**

The use is versatile due to unification of the frame mounting latches for all WDS profile systems.

**Usage:** Glazing for balconies, office dividers, lobby type entrance structures, etc.

**Recommendations:** H-connector is designed to connect two frames, when static improvement of frames connection isn't required. It is recommended to use H-connector in structures not exceeding 1.8 m in height (depending on the width of the structure).

While assembling the structures with H-connector (item 024), it is recommended to perform additional sealing for joints abutting to the frames as indicated in the drawings.

**82 mm** **WDS 8S**  
 Sash 047 // Frame 046 // H-connector 024 // Frame 046  
 $J_x = 4,5 \text{ cm}^4, J_y = 3,6 \text{ cm}^4$

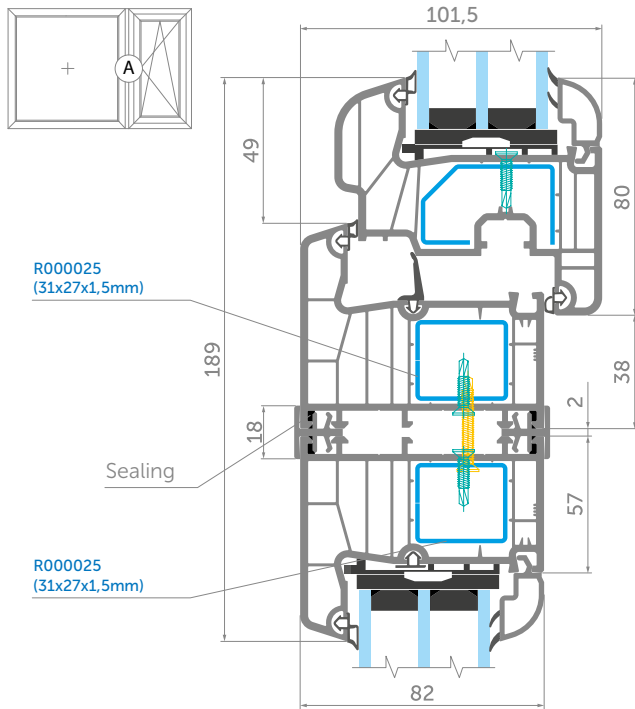

**70 mm** **WDS 7S**  
 Sash 060(093) // Frame 059(092) // H-connector 074 // Frame 059(092)  
 $J_x = 4 \text{ cm}^4, J_y = 1,9 \text{ cm}^4$

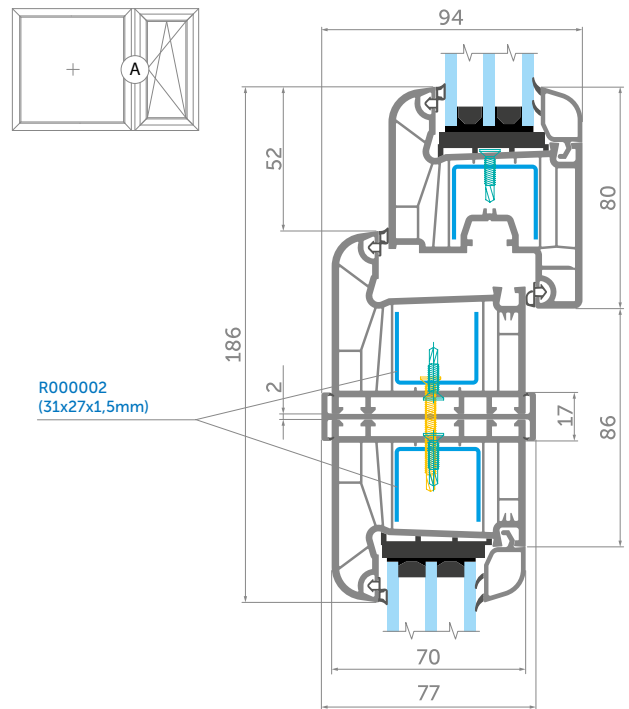

**70 mm** **WDS 6S**  
 Sash 089 // Frame 088 // H-connector 074 // Frame 088  
 $J_x = 3,6 \text{ cm}^4, J_y = 1,3 \text{ cm}^4$

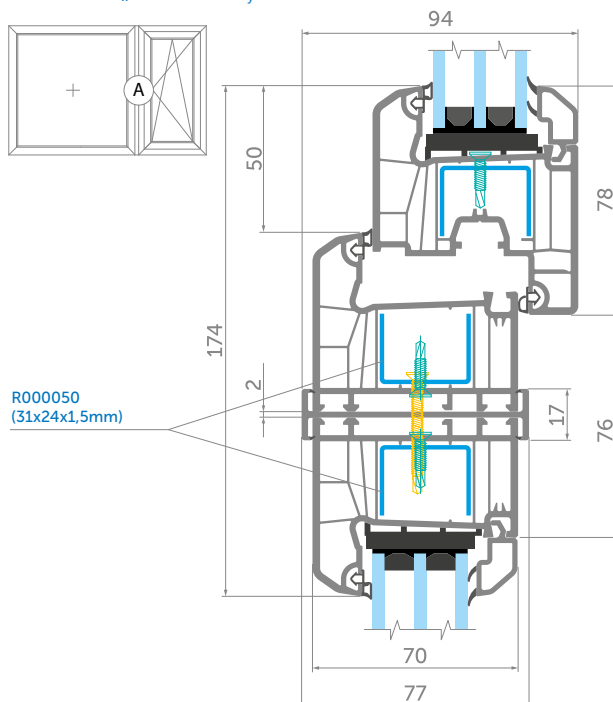

**60 mm** **WDS 5S**  
 Sash 087 // Frame 086 // H-connector 075 // Frame 086  
 $J_x = 3,6 \text{ cm}^4, J_y = 1,3 \text{ cm}^4$

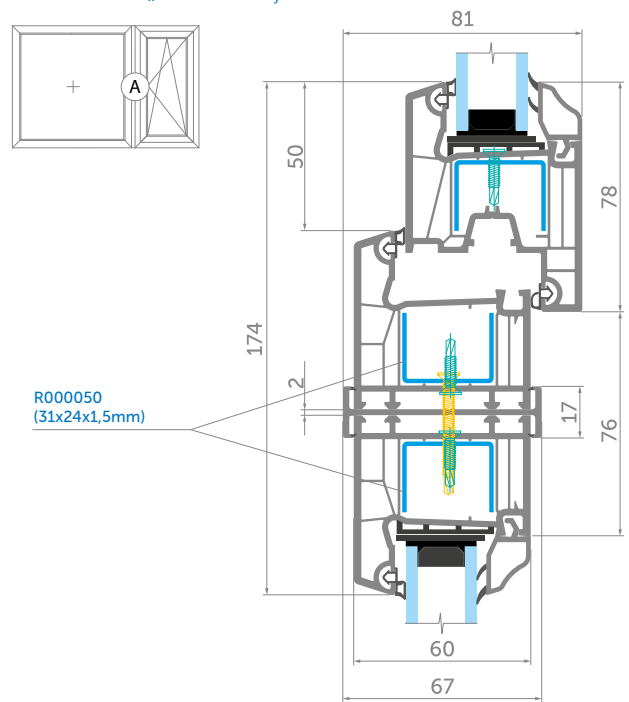

# Connection with I-connector 076

WDS I-connector can be used for profile systems with 60, 70, 82 mm mounting width.

**Usage:** Frames connection and joint rigidity improvement. Connector high inertia moment enables to make constructions up to 3.5 m in height.

**Recommendations:** Reinforcing profile of connector must always be secured in the window aperture.

**82 mm** **WDS 8S**  
 Sash 047 // Frame 046 // I-connector 076 // Frame 046  
 $J_x = 22,4 \text{ cm}^4, J_y = 4,7 \text{ cm}^4$

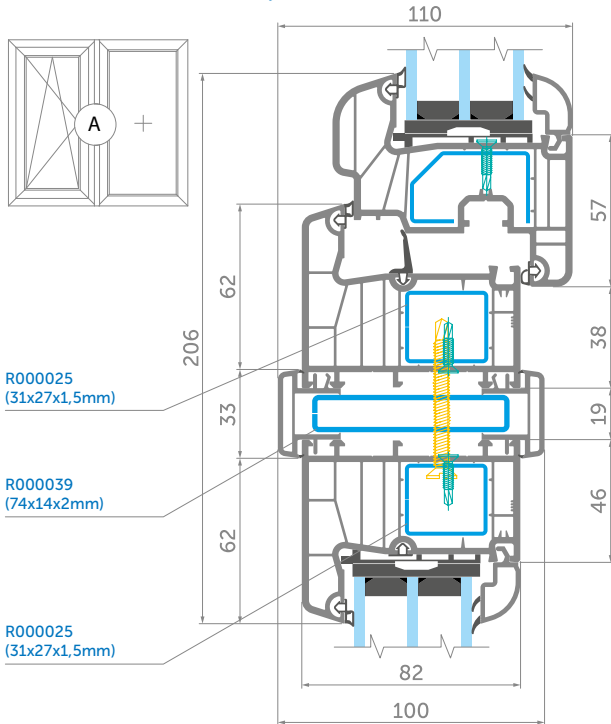

**70 mm** **WDS 7S**  
 Sash 060(093) // Frame 059(092) // I-connector 076 // Frame 059(092)  
 $J_x = 21,9 \text{ cm}^4, J_y = 2,9 \text{ cm}^4$  (R000039 reinforcement)  
 $J_x = 16,0 \text{ cm}^4, J_y = 2,8 \text{ cm}^4$  (R000007 reinforcement)

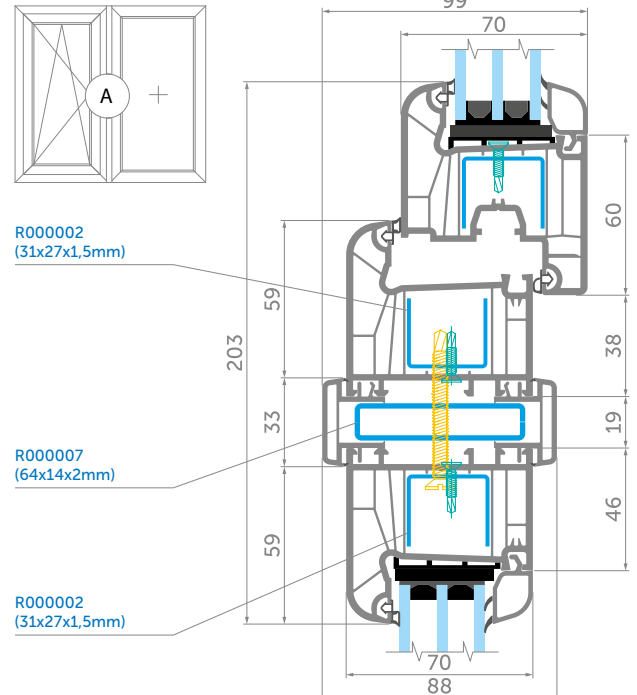

**70 mm** **WDS 6S**  
 Sash 089 // Frame 088 // I-connector 076 // Frame 088  
 $J_x = 21,5 \text{ cm}^4, J_y = 2,4 \text{ cm}^4$  (R000039 reinforcement)  
 $J_x = 15,6 \text{ cm}^4, J_y = 2,3 \text{ cm}^4$  (R000007 reinforcement)

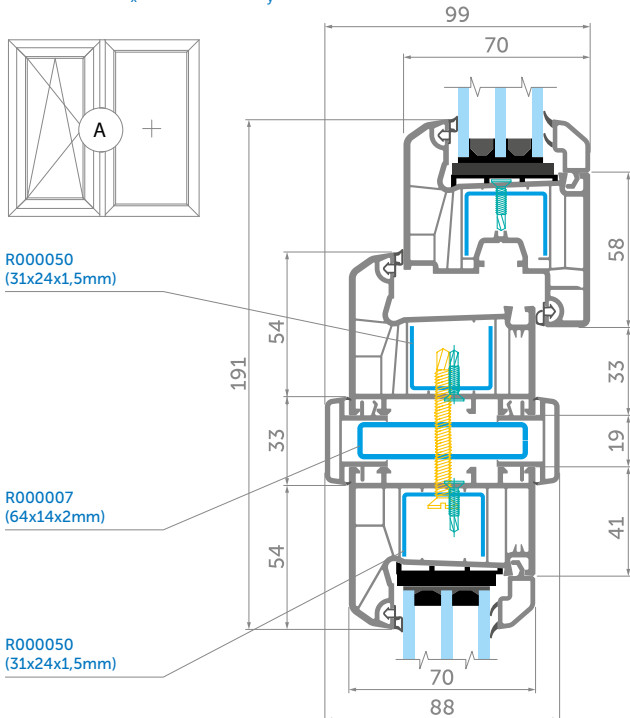

**60 mm** **WDS 5S**  
 Sash 087 // Frame 086 // I-connector 076 // Frame 086  
 $J_x = 15,6 \text{ cm}^4, J_y = 2,3 \text{ cm}^4$  (R000007 reinforcement)

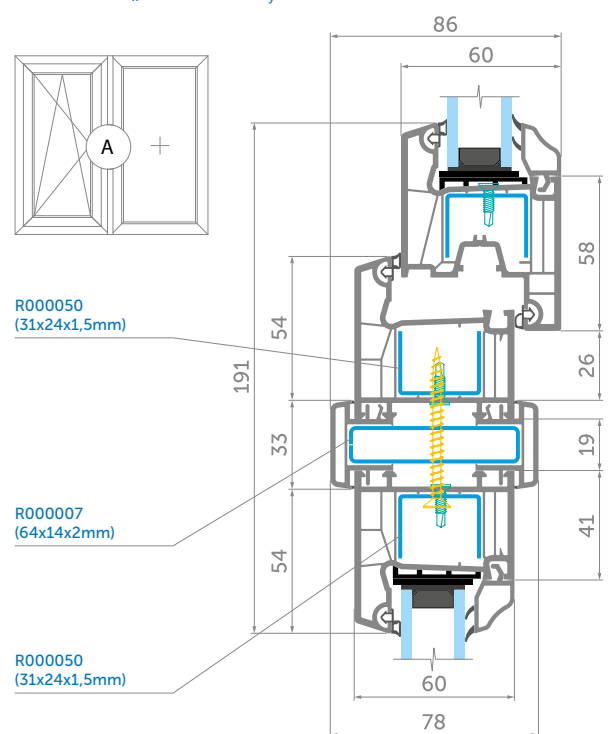

# Connection with I-connector 035

**WDS I-connector can be used for profile systems with 60, 70, 82 mm mounting width.**

**Usage:** Frames connection and joint rigidity improvement. Connector high inertia moment enables to make constructions up to 3.5 m in height.

**Recommendations:** While assembling the structures, it is necessary to perform additional sealing for joints abutting to the frames as indicated in the drawings. For sealing material, you can use technical silicone, polyethylene foam or polystyrene, fly screen spline or tubular seal of EPDM, PVC, TPV. Reinforcing profile of I-connector must always be fixed in the window aperture.

**82 mm** **WDS 8S**  
 Frame 046 // I-connector 035 // Frame 046 // Sash 047  
 $J_x = 64,9 \text{ cm}^4$ ,  $J_y = 4,1 \text{ cm}^4$

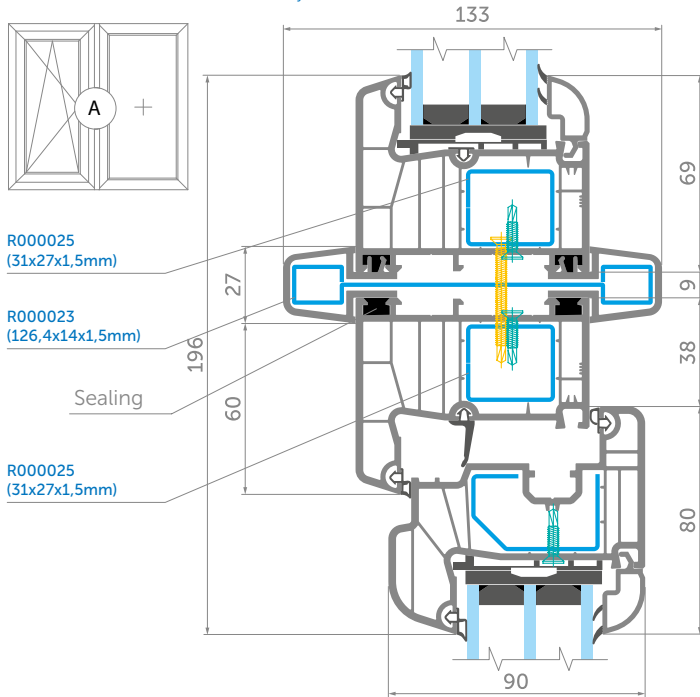

**70 mm** **WDS 7S**  
 Frame 059(092) // I-connector 035 // Frame 059(092) // Sash 060(093)  
 $J_x = 38,1 \text{ cm}^4$ ,  $J_y = 2,2 \text{ cm}^4$

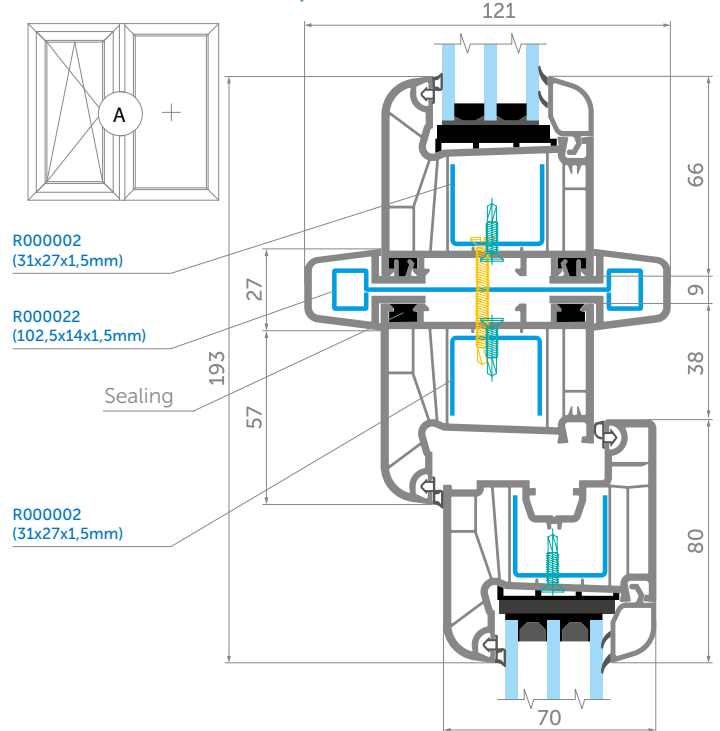

**70 mm** **WDS 6S**  
 Frame 088 // I-connector 035 // Frame 088 // Sash 089  
 $J_x = 37,7 \text{ cm}^4$ ,  $J_y = 1,7 \text{ cm}^4$

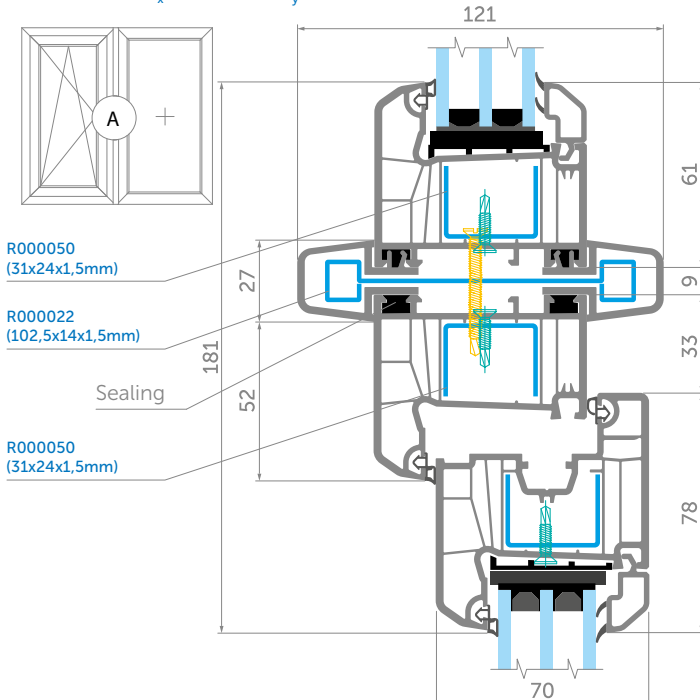

**60 mm** **WDS 5S**  
 Frame 086 // I-connector 035 // Frame 086 // Sash 087  
 $J_x = 37,7 \text{ cm}^4$ ,  $J_y = 1,7 \text{ cm}^4$

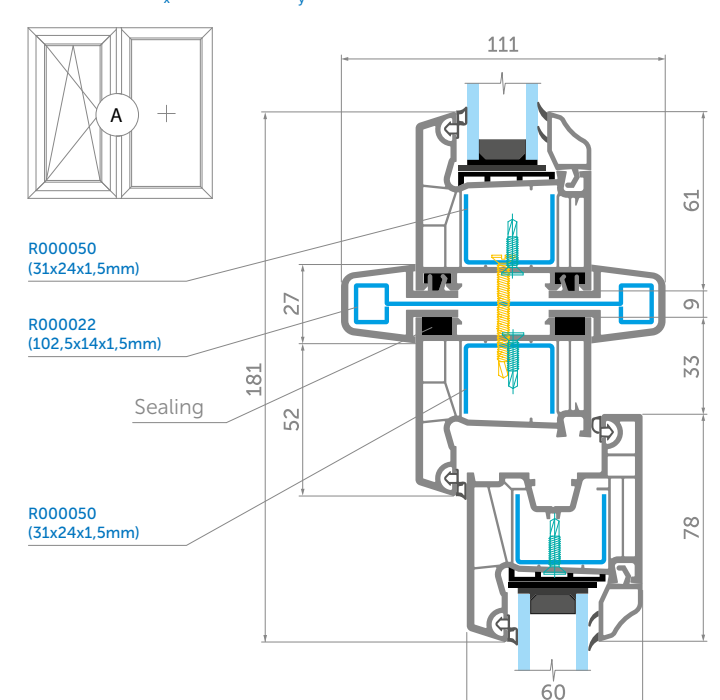



# Structural connection at different angles

Circular connector (pipe) in WDS profile systems enables facade glazing at different angles.

**Usage:** For the creation of separate enclosures inside the buildings or separate premises, as well as for the construction of external 'warm' structures.

**Recommendations:** In order to determine the required dimensions for the structure, it is recommended to use the data indicated in the tables below.

Reinforcing profile of circular connector must always be fixed in the window aperture.

**82 mm** **WDS 8S**  
 Frame 046 // Pipe adaptor 052 // Pipe 051 //  
 Pipe adaptor 052 // Frame 046  
 $J_x = 12 \text{ cm}^4, J_y = 11,1 \text{ cm}^4$

Angle, °	A, mm	B, mm
90	89	7
95	85,5	10,5
100	82,5	13,5
105	79,5	16,5
110	76,5	19
115	74	18
120	71,5	20,5
125	69,5	23
130	67	29
135	65	31
140	63	33
145	61	35
150	59	37
155	57	39
160	55	40,5
165	53,5	42,5
170	51,5	44,5
175	49,5	46
180	48	48

**70 mm** **WDS 7S**  
 Frame 059(092) // Pipe adaptor 053 // Pipe 051 //  
 Pipe adaptor 053 // Frame 059(092)  
 $J_x = 11,5 \text{ cm}^4, J_y = 9,4 \text{ cm}^4$

Angle, °	A, mm	B, mm
90	81,5	11,5
95	78,5	14,5
100	76	17
105	73,5	19,5
110	71	22
115	68,5	24
120	66,5	26
125	64,5	28
130	62,5	30
135	61	32
140	59	33,5
145	57,5	35,5
150	56	37
155	54	38,5
160	52,5	40
165	51	42
170	49,5	43,5
175	48	45
180	46,5	46,5

**70 mm** **WDS 6S**  
 Frame 088 // Pipe adaptor 053 // Pipe 051 //  
 Pipe adaptor 053 // Frame 088  
 $J_x = 11,2 \text{ cm}^4, J_y = 8,9 \text{ cm}^4$

Angle, °	A, mm	B, mm
90	81,5	11,5
95	78,5	14,5
100	76	17
105	73,5	19,5
110	71	22
115	68,5	24
120	66,5	26
125	64,5	28
130	62,5	30
135	61	32
140	59	33,5
145	57,5	35,5
150	56	37
155	54	38,5
160	52,5	40
165	51	42
170	49,5	43,5
175	48	45
180	46,5	46,5

**60 mm** **WDS 5S**  
 Frame 086 // Pipe adaptor 084 // Pipe 051 //  
 Pipe adaptor 084 // Frame 086  
 $J_x = 11,2 \text{ cm}^4, J_y = 8,9 \text{ cm}^4$

Angle, °	A, mm	B, mm
70	96	10,5
75	92	14
80	88	16,5
85	84,5	19
90	81,5	21,5
95	78,5	23,5
100	76	25,5
105	73,5	27
110	71	29
115	68,5	30,5
120	66,5	32
125	64,5	33,5
130	62,5	34,5
135	61	36
140	59	37,5
145	57,5	38,5
150	56	39,5
155	54	41
160	52,5	42
165	51	43
170	49,5	44
175	48	45,5
180	46,5	46,5
185	45	47,5
190	43,5	48,5
195	42	49,5
200	40	51
205	38,5	52
210	37	53
215	35,5	54,5
220	33,5	55,5
225	32	56,5
230	30	58
235	28	59,5
240	26	61

## Structural connection at an angle of 90°

90° corner adaptor can be applied to profile systems with 60 mm and 70 mm mounting width.

**Usage:** Glazing for balconies, office dividers, lobby type entrance structures, etc.

**Recommendations:** When calculating the dimensions for frame structures with corner adaptor 120, it is necessary to subtract 62 mm for each side from overall size, for frame structures with corner adaptor 069 it is necessary to subtract 80 mm for each side.

While assembling the structures with 90° corner adaptor (item 120), it is necessary to perform additional sealing for joints

abutting to the frames as indicated in the drawings. For sealing material, you can use technical silicone, polyethylene foam or polystyrene, fly screen spline or tubular seal of EPDM, PVC, TPV.

Reinforcing profile of corner adaptor must always be fixed in the window aperture.

90° corner adaptor can be applied only for the right angle.

If you are not sure that the angle is 90°, you should apply circular connector.

**70 mm** **WDS 7S**  
 Frame 059(092) // Corner adaptor 069 // Frame 059(092)  
 $J_x = 10 \text{ cm}^4, J_y = 10 \text{ cm}^4$

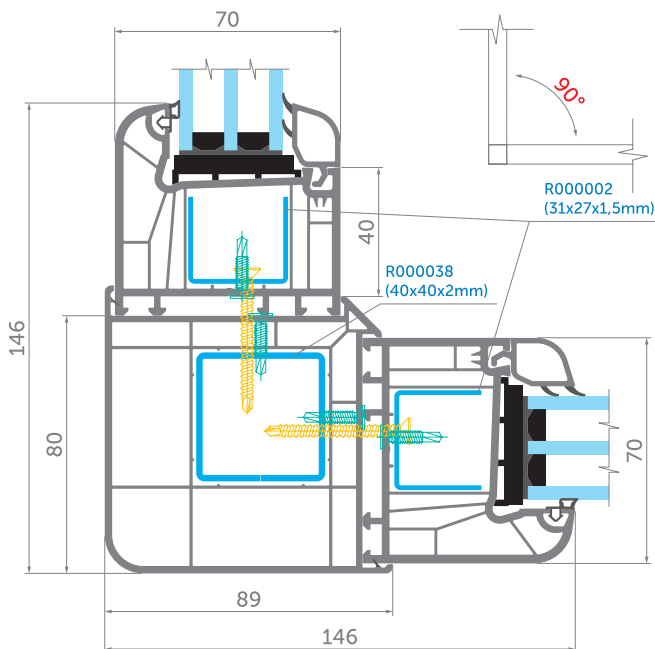

**70 mm** **WDS 6S**  
 Frame 088 // Corner adaptor 069 // Frame 088  
 $J_x = 9,6 \text{ cm}^4, J_y = 9,6 \text{ cm}^4$

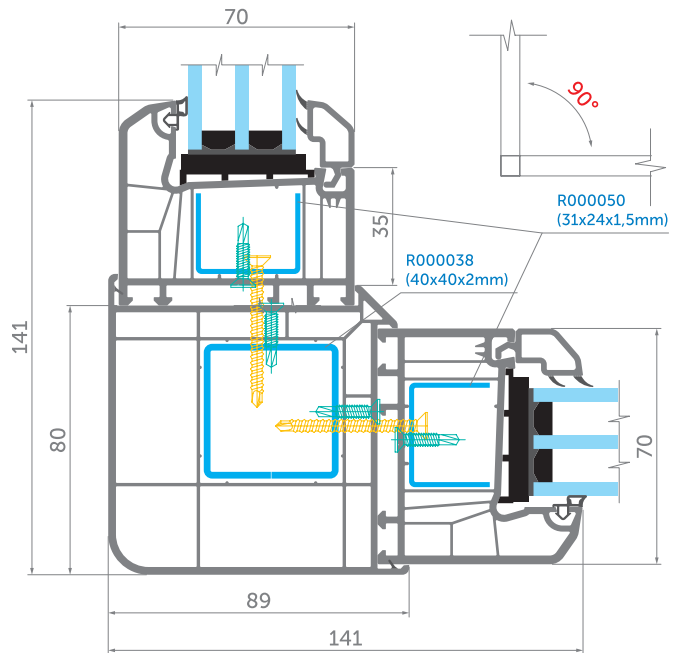

**60 mm** **WDS 5S**  
 Frame 086 // Corner adaptor 120 // Frame 086  
 $J_x = 9,6 \text{ cm}^4, J_y = 9,6 \text{ cm}^4$

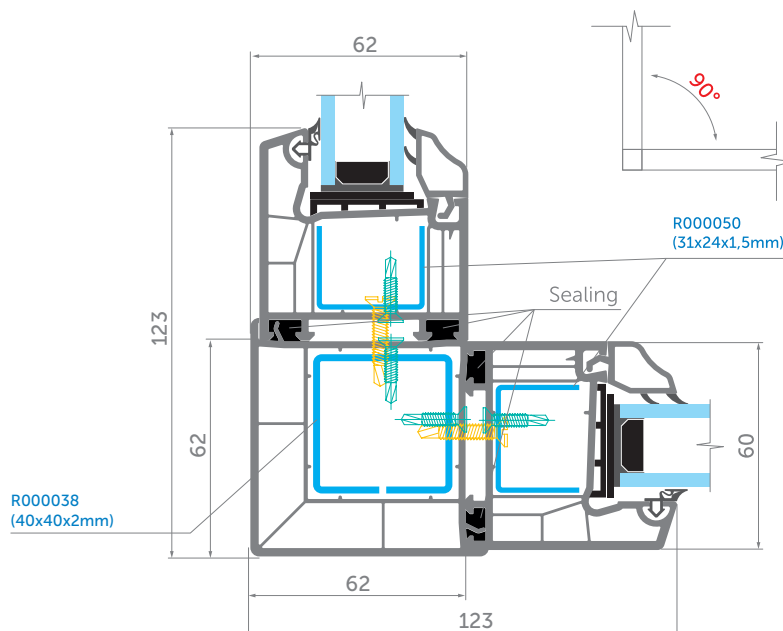

# Connection with reinforcement cover profile

Reinforcement cover profile can be used with all WDS systems.

It is designed to improve the statics of finished structures.

## Usage:

1. Improvement of static indicators in structures that have already been installed.

2. Achievement of the required static performance in the design of new structures.

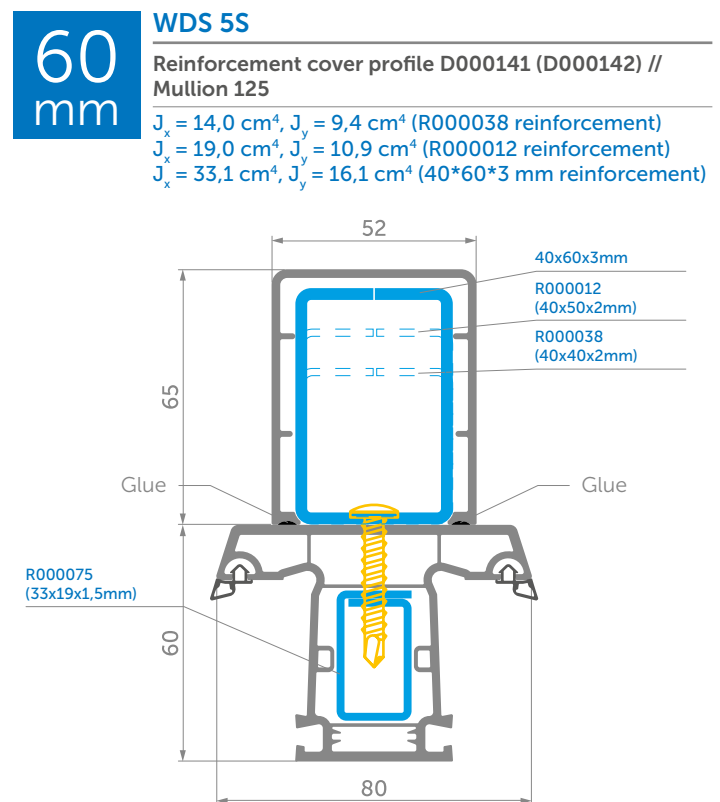
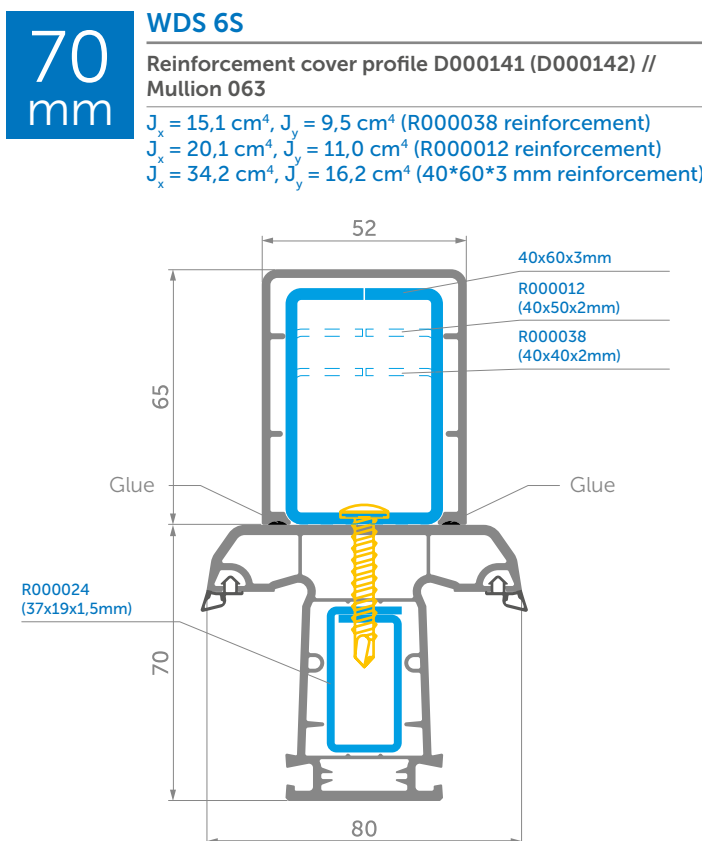
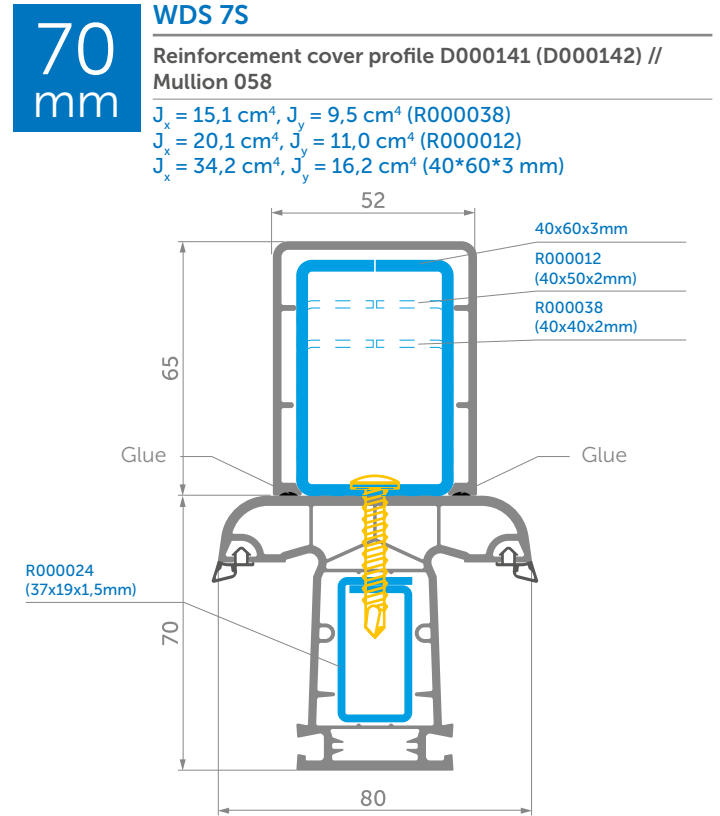
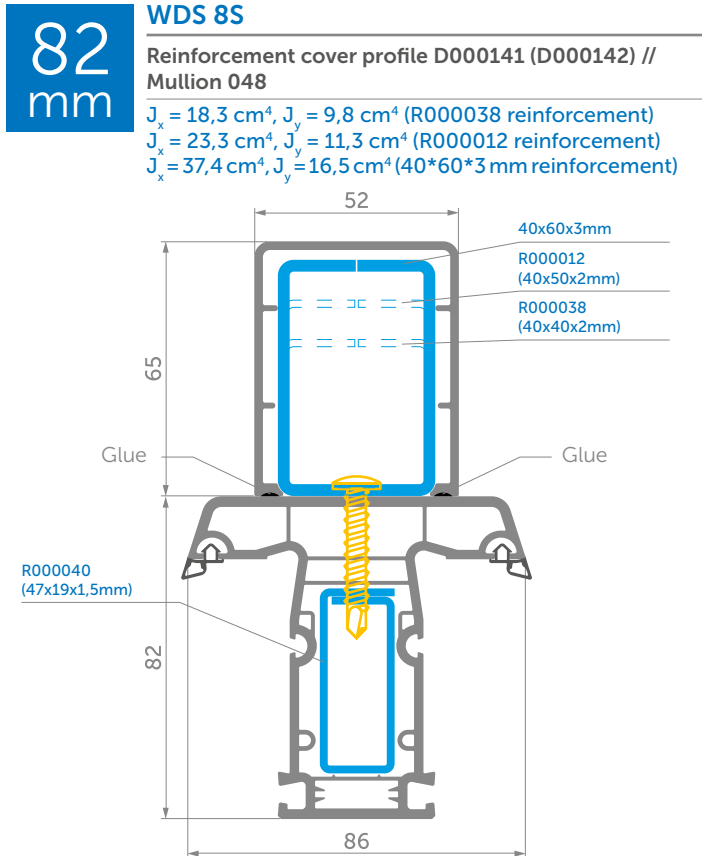

# Connection with frame extension

WDS 40 mm and 100 mm frame extensions can be used for profile systems with 60, 70, 82 mm mounting width.

**Usage:** Height adjustment in frame facade part to the high fillister in the window aperture. Extending the frame in case of future need to lower the ceiling or raise the floor. If the necessary extension of frame must be over 40 mm, 100 mm frame extension should be used (item 070).

**Recommendations:** When using 100/70 frame extension with WDS 8S profile system, it is recommended to base its front plane with that frame plane, which will be the visible part of the window structure (as shown in 2 examples).

While assembling the structures with frame extension 043, it is recommended to perform additional sealing for joints abutting to the frames as indicated in the drawings.

## 60 mm WDS 5S

Frame 086 // Frame extension 013

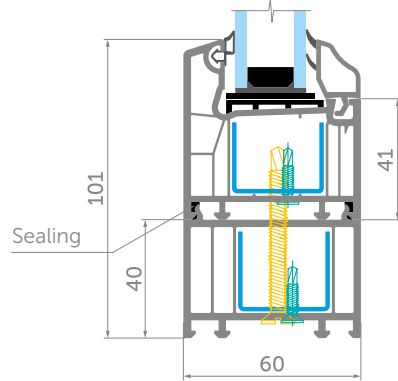

## 70 mm WDS 6S

Frame 088 // Frame extension 043  
Frame 088 // Frame extension 070

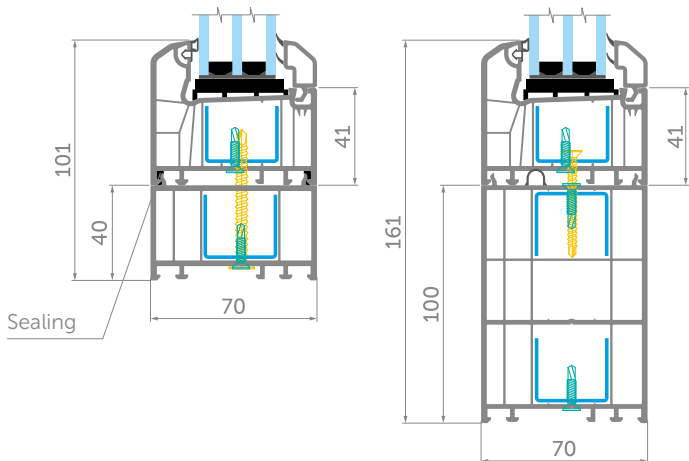

## 70 mm WDS 7S

Frame 059(092) // Frame extension 043  
Frame 059(092) // Frame extension 070

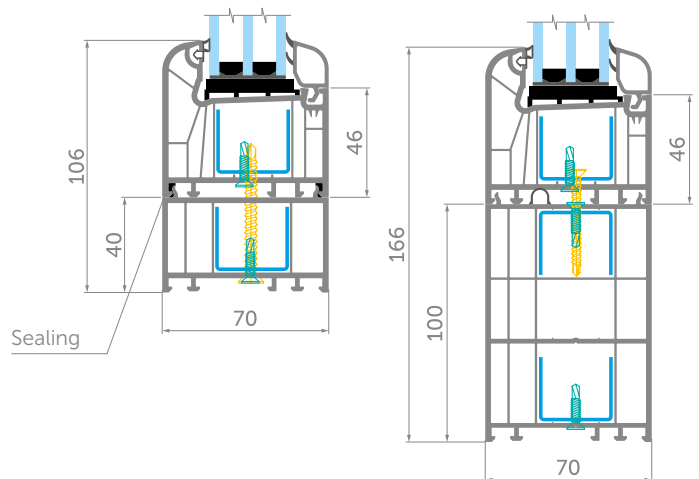

## 82 mm WDS 8S

Frame 046 // Frame extension 083

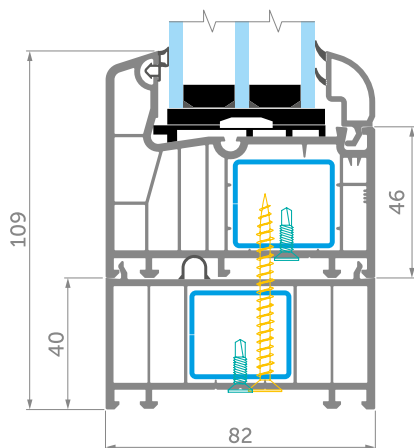

## 82 mm WDS 8S

Frame 046 // Frame extension 070

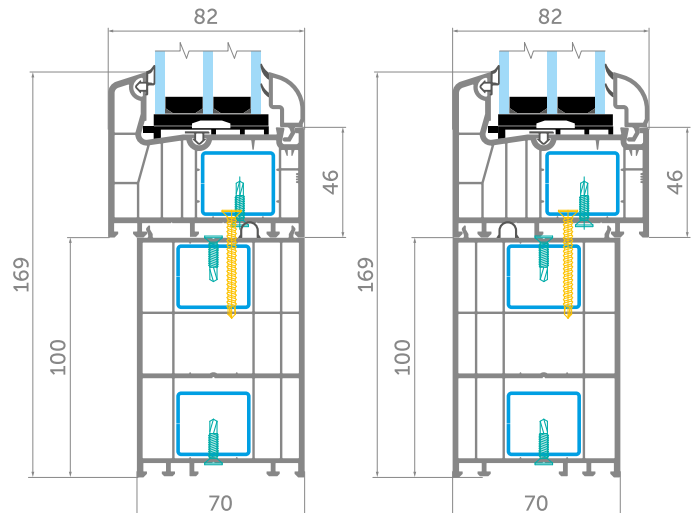

## Connection with fixed frame

WDS fixed frame (item 077) can be used for profile systems with 70 and 82 mm mounting width. 60 mm systems should be assembled with fixed frame (item 050).

**Usage:** 1. For facilitation of metal plastic window transportation. Bottom frame surface often touches floor during transportation. Fixed frame prevents from window frame deformation and damage.

2. For fixation of windowsill from one side and drip strip from another. Fixed frame is completed with leg for windowsill fixation (item 077). Provides additional thermal insulation of field weld. It is completed with seal for tighter connection to frame bottom part.

82  
mm

### WDS 8S

Sash 047 // Frame 046 // Fixed frame 077

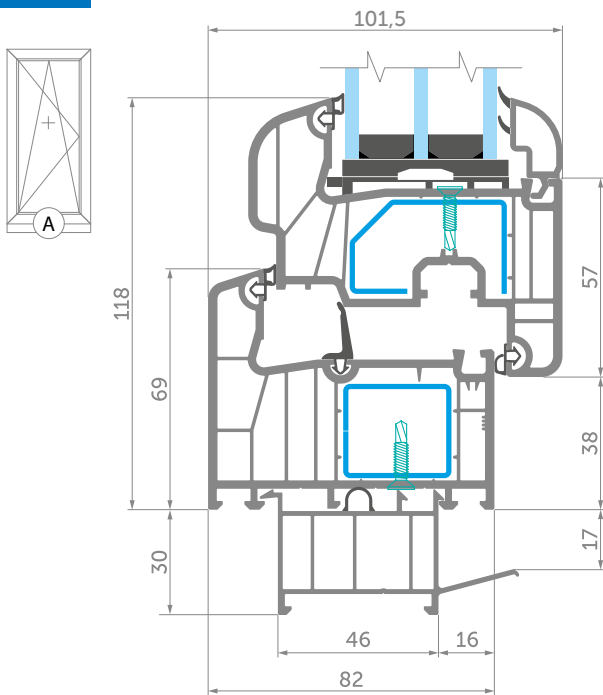

70  
mm

### WDS 7S

Sash 060(093) // Frame 059(092) // Fixed frame 077

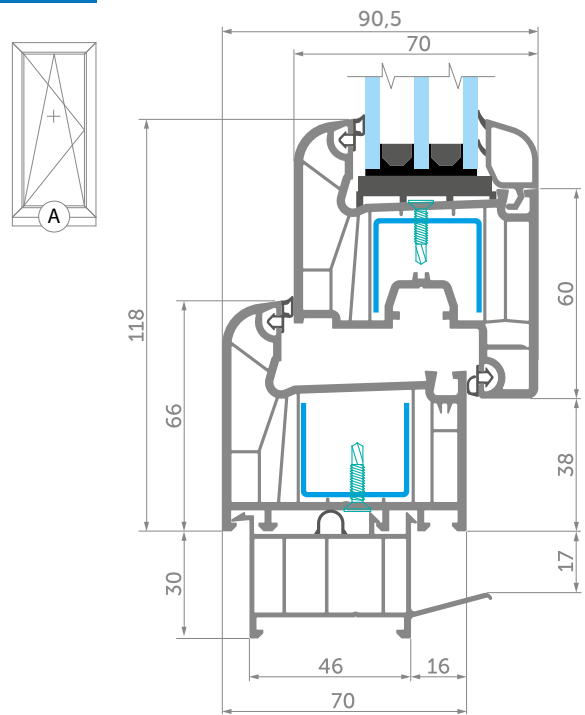

70  
mm

### WDS 6S

Sash 089 // Frame 088 // Fixed frame 077

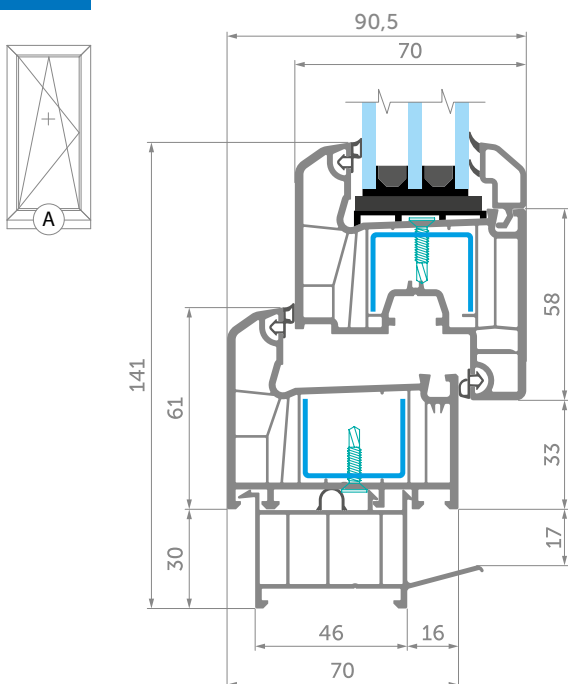

60  
mm

### WDS 5S

Sash 087 // Frame 086 // Fixed frame 050

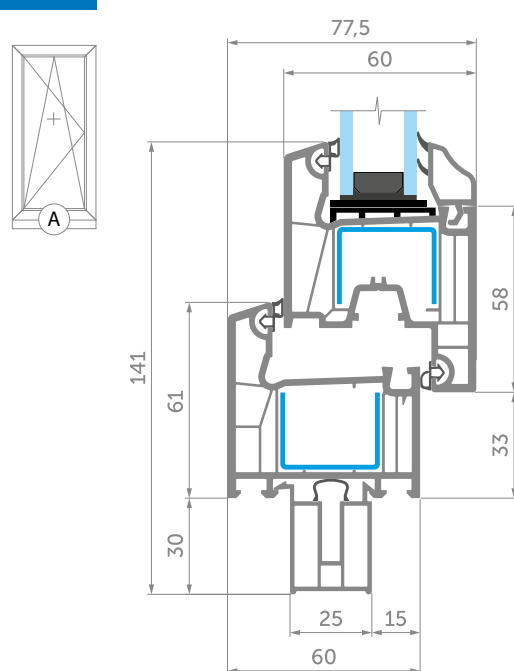





10, Kursantska str., Dnipro,  
49051, Ukraine

e-mail: [info@wds.ua](mailto:info@wds.ua)

[wds.ua](http://wds.ua)

